

**how  
to  
build  
RAMPS  
for  
home  
accessibility**

---

**THE RAMP PROJECT**

---

# ACCESSIBLE RAMPS

## RAMP DESIGN FOR INDIVIDUAL SITUATIONS

Ramps are an important feature in accessing a home or agricultural building. This applies not only to people who use wheelchairs but also to those who have difficulty climbing stairs, such as people who have arthritis or hemiplegia and those who use walkers, crutches or canes. To be safe and most effective, ramps should be built with a few basic guidelines in mind.

*Slope:* Slope is the term used to describe how steep a ramp is. The slope is extremely important because it affects how difficult it is to travel up and down the ramp. **If the slope is too steep, the ramp may be too difficult for someone to use or may even be unsafe.**

### Comparison of 1:12 and 1:20 slopes

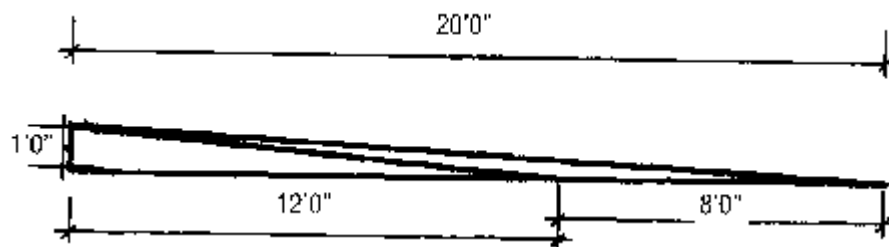

A gentler slope has less resistance for either walking or wheeling.

The 1 to 12 slope should be seen as the steepest slope to be built and may be too steep for some people.

*Width:* The width of the ramp should be at least 36 inches.

Before building a ramp ask this question:

**"Is a ramp the best solution?"**

There may be alternatives available that will do a better job of meeting the needs of all of the people involved. Sometimes a new set of long-trend low-riser steps can be built for a person using canes, crutches or a walker. Sometimes, a lifting device can be used rather than building a ramp. Consider the length of time the access solution is likely to be needed. If the anticipated need is quite short, it may be cost-

effective to consider alternate living arrangements. Many factors need to be evaluated in order to come up with the solution that best meets your needs. Assistance for access planning may be available from a Center for Independent Living in your area.

Consider these points once you have decided that a ramp is the best solution.

- Who's the primary user?
- What type of assistive device does the person use (cane, crutches, walker, manual or electric wheelchair, motorized 3-wheel cart)?
- Will the person's abilities change? Plan for anticipated changes.
- Will the person use the ramp independently or will help be needed?
- Who will provide help and what are that person's abilities?
- Which entryway is best for the ramp? Consider the inside as well as outside. Narrow doors or hallways can prevent access to a doorway from the inside.
- Placement of existing door handles and swing direction of doors.
- Where does the person want to go most often (garage, driveway, front sidewalk)? Where is the best place to access transportation?
- If there is an attached garage, can a ramp be placed inside?
- How will the ramp affect available yard space?
- Are there barriers such as trees, shrubs, poles, etc.?
- How will the ramp appear?
- What are the local zoning requirements for lot lines and setbacks?
- What will the cost be? Is there help available for financial assistance if needed?

*Getting a Ramp Built:* With information and materials available from most local building supply stores, an individual with ordinary carpentry skills can fabricate his or her own ramp. This is clearly demonstrated by the millions of homemade decks that have been constructed over the past few years. If a person lacks the basic carpentry skills, a local carpenter or contractor should have little trouble constructing a ramp. **However, don't assume the builder you choose will have knowledge of the guidelines for ramps included in this publication.** If the builder is unfamiliar with ramps for use by people with disabilities, a copy of this publication or similar information regarding guidelines for ramp construction should be provided to the builder to avoid an unsafe or unusable structure.

**Remember who the user will be-it won't be the builder.**

In cases where financial resources are limited, the ramp might become a public service project of a local service organization, school carpentry class, carpenter's union, or vocational agriculture class. Contact one of these groups or the local Easter Seal Society, Office of Vocational Rehabilitation, or volunteer hotline for possible assistance.



Long-tread, low-riser steps

The modular ramp design creates the possibility that ramps will become easily recyclable. The design allows flexibility in creating various length runs of sloped surface and pre-made modules can be matched to custom segments built on-site to create the needed ramp. The width of the ramp can be tailored to individual needs by changing the width of each module. Usually the landing at the doorway will require customization and sometimes the ground level end of the ramp will need to be modified to meet the site conditions. Having reusable components for the majority of the ramp reduces costs and increases the possibility of obtaining either short-term or long-term access.



**Example of bad ramp:** This ramp is 8' too short. There is no level landing, guardrail, or wheel stop, and the lip at the bottom is not flush to the ground. A contractor designed and built it for \$550.



**Example of a good ramp:** 20' of sloped surface for 18" rise. Volunteers built it for \$625.

Ramps are built for people who can't use stairs, or need a gentler, less stressful way to change levels. A successful home ramp building project requires careful planning, because compromises may have to be made among many competing needs - of the person with a disability, other household members, budget available, security concerns, appearance, property market value. The following information should guide you in this planning process.

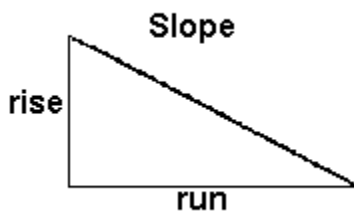

---

***Slope:*** A ramp's slope - the angle of the inclined surfaces - is perhaps a project's most critical consideration, because of its impact on layout requirements, the expense involved, and the ramp's ultimate usefulness. Slope is the right-angle relationship of vertical height (rise) to horizontal length or projection (run). It is usually expressed as a ratio of these two measurements, with the rise figure frequently set at a unit of one. For example, a slope of 1:12 means that as each dimension unit of height changes, the other right-angle side projects out 12 units, which together result in a certain angle for the inclined, third side of the triangle.

### Comparison of slopes

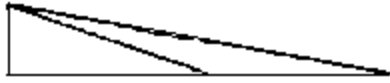

It's important to point out that the larger the run figure in a slope ratio, the **gentler** the angle for the inclined surface will be - a 1:16 slope, for example, is **not** as steep as a 1:12 slope. This fact is a source of initial confusion for many people, who conceptualize that a bigger number must mean a steeper slope. A comparative drawing (below) shows that it's exactly the opposite situation.

### **SAFETY ADVISORY:**

There may be a temptation to build a ramp that is steeper than the recommended 1 to 12 minimum in order to conserve space or reduce costs. Before deciding to build such a ramp, remember that the steeper the ramp is, the more dangerous it becomes to anyone using it. Ramp Project personnel have replaced steep ramps that have caused falls resulting in serious injuries and ramps that were so steep that the person needing it could not use it independently.

**DO NOT BUILD RAMPS THAT ARE STEEPER THAN 1 TO 12 UNLESS** you have considered all the choices and your particular situation leaves you with no other choice. Safety and independence are far more important than short-term savings or having a little less space.

The issue of how to choose a slope for a residential ramp isn't clearly addressed in the codes or handbooks, and is another source of confusion for many people. Minnesota has a section in its building code - Chapter 1340 - that mandates the design for certain accessibility features that must be installed in public/commercial settings. Chapter 1340 mandates slope ratios for ramps built for public/commercial properties within the state, but single-family residences are exempt from having to comply with these code requirements because each ramp's design must be tailored for a particular person's and home's circumstances.

For ramps in public/commercial settings, separate maximum slopes for exterior and interior ramps are actually set in the code. Interior and protected ramps may

have slopes up to a 1:12, while exterior ramps (which in precise code language are referred to as "walks") must have gentler slope not exceeding 1:20. Because the code uses a 1:20 slope for exterior ramps, many people make the assumption that this is the only slope that can be used at houses as well.

In actuality, ramps for homes can be built at many different slopes and still be "right". For many households, the selection process requires balancing the desire for a very gentle slope with the amount of construction/cost involved, yard space that must be used, and appearance. The one general guideline that should be followed is that the slope should not exceed 1:12. Slopes steeper than this may be beyond the strength of many people using manual chairs, and may also cause an ascending electric wheelchair to tip backwards from a weight imbalance due to the low position in which the chair's battery pack is carried. They can also cause or aggravate back problems for helpers pushing a chair up a ramp, or controlling a chair traveling down one.

The slope determination process starts by first establishing how much total rise has to be covered. Two measurements must be checked to determine this figure. The first figure is the distance from the exit door's sill down to the ground, or "grade", at the house's foundation. Since a ramp is constructed a certain distance out from the house into the yard, though, any change in grade in the area for the ramp's construction also must be taken into account. For example, if the change in grade from a home's doorsill to the ground at the foundation is 29", and the yard out where the ramp will be sited is flat-no change in grade-then the total rise that must be covered is 29".

However, if the change in grade at another house's foundation is 29" (a), but the yard where the ramp will be located drops away another 13" (b), then the total rise

that must be covered is 42" (c). (See below)

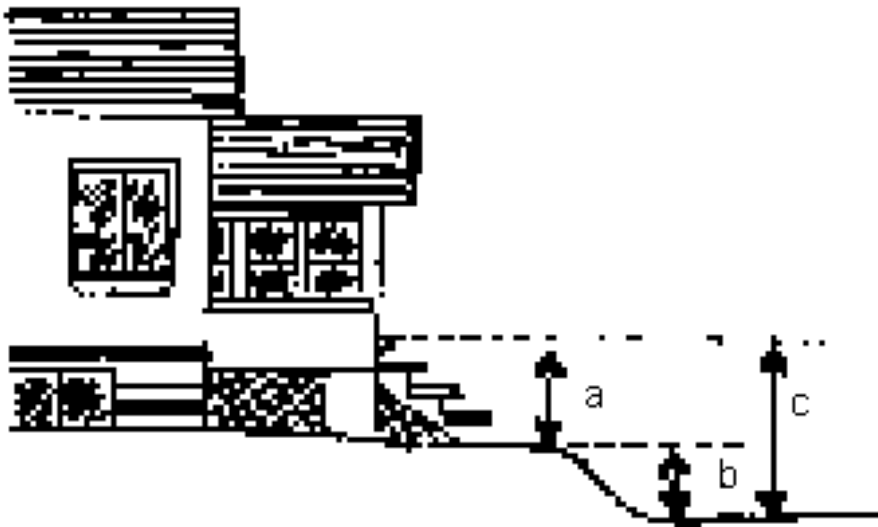

Once total rise (typically stated in inches) is determined, it is then multiplied by the slope (in inches) chosen, to obtain the total amount of horizontal projection (in inches) required to achieve the particular slope. Dividing this figure by 12 converts it into a more workable measurement of feet of horizontal projection required. For example, say that a ramp with a 1:12 slope is to be built at the home with a 29" total rise described above. The required horizontal projection is  $29" \times 12" = 348"$ , or when converted to feet, 29'. Say, however, that a ramp with a gentler slope-a 1:16-is desired.  $29"$  of total rise  $\times 16"$  of slope = 464", and when divided by 12 to convert to feet, equals over 38 feet of horizontal projection needed.

It's important to note that the resulting figure is a measurement of amount of horizontal projection the layout must contain to achieve a desired slope. It is not a measurement of distance traveled along the inclined surface, as some people mistakenly believe, and it **doesn't** include any distances/areas required for necessary landings-these are extra.

### **To compute Slope Ratio**

Each inch of height requires a certain number of inches in distance to provide a slope.



Multiply inches of rise (29" as an example) by the ratio you want, getting inches first and then dividing by 12 to convert to feet.

<b>1 to 20</b>		<b>1 to 12</b>
$  \begin{array}{r}  20 \\  \times 29 \\  \hline  580  \end{array}  $	= rise = length (inches)	$  \begin{array}{r}  12 \\  \times 29 \\  \hline  348  \end{array}  $
divide by 12 (to convert to feet)		
<b>48' 4"</b>		<b>29'</b>

**LENGTH OF SLOPE IN FEET**

---

**Landings:** Landings are the level areas required at the top, bottom, and sometimes at intermediate locations in a rampway. These areas allow a person to maintain balance while performing tasks like opening doors, transferring in and out of a vehicle, resting for a time, and safely changing direction of travel when a ramp makes a turn. Recommended landing sizes are based on these functions.

**Top Landings:** Top landings should be nearly flush with the exterior door threshold. 1/2" is the typical maximum, particularly when a wheelchair user is involved-anything larger will abruptly stop a chair's relatively small front wheel, or is a tripping hazard for walkers. Pay attention, too, to threshold specs if a new primary door is being installed. If a prehung unit's going in, most don't have the low threshold that's needed here.

For homes on footed foundations, it's advisable in most parts of the state to bolt the top landing into the home's foundation. This will avoid the potential problem of the relatively lightweight ramp landing lifting up due to frost heave and jamming under an outswinging door (like a storm door). For unfooted structures, or temporary foundations such as mobile homes on blocks, bolting the landing may still be appropriate, but the ramp shouldn't be footed for the opposite reason. Local soil conditions -e.g., clay vs. loam- will also play a definite role here.

Top landings at minimum should be at least 60" X 60" if there is an outswinging door, with at least a 12" to 24" of "elbow room" space provided off the door's handle side, particularly for a person using mobility equipment. These dimensions give enough room for a person to move off to the side while opening the door without having to back up to get out of the way of its swing. If there is no outswinging door, the landing may be somewhat narrower- probably 48" at minimum.

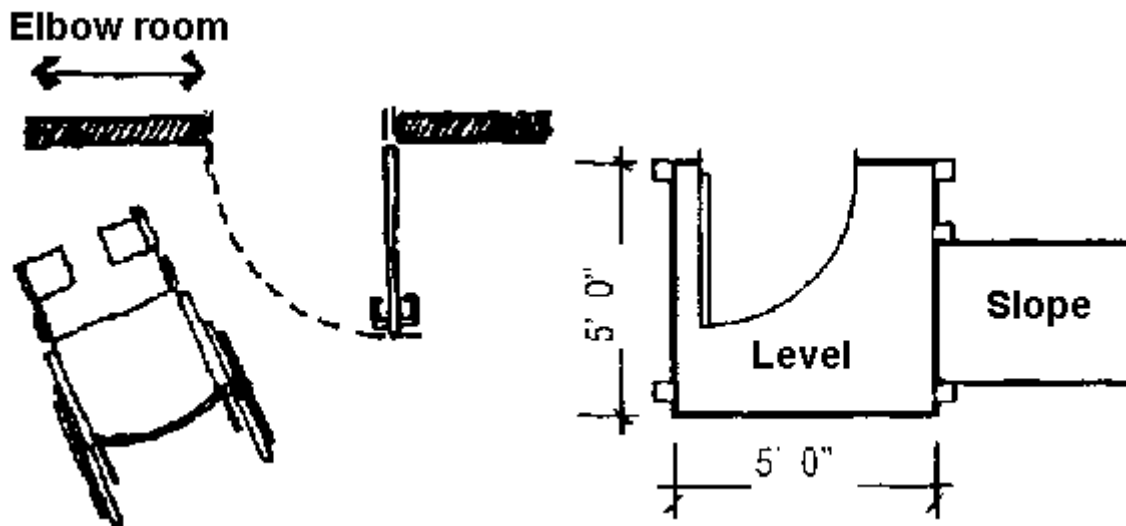

**Intermediate Landings:** Intermediate landings for a long, in-line run of ramp can have the same width as the running surface's, and length can range from 36" to 60"-the slope chosen is a factor to account for here, with a steeper slope like a 1:12 requiring a longer distance in which to stop when descending. A rough guideline to use is to install an intermediate landing if a section of ramp covers more than a 30" change in rise, but persons with limited stamina/control may need one sooner than this. Dimensions for intermediate landings where a direction change occurs depend on ramp width and the user's circumstances. When a chair user's involved, a 48" X 48" landing for a 90 degree turn is comfortable; for an 180 degree turn, 48" by twice the width of the two ramp sections is typical.

**Bottom Landings:** For bottom landings, typical minimum dimensions when in-line travel is involved are as wide as the ramp by about 48" long for someone walking, and about 60" to 72" for a chair user. Larger-width landings may be called for if the person has to make a direction change (e.g. 90-degree turn). Make sure the

ramp/landing intersection doesn't have a "lip" greater than 1/2" which would become a tripping/rolling hazard.

## Rampway Widths and Running Surface Features

Running surface widths can range from 36" to 48", depending on the personal assistance or mobility equipment involved. 36" may be appropriate for someone walking or using a cane, crutches, or a walker. (32" may be appropriate for persons who need to lean on both railings when moving.) 42" to 48" is appropriate for someone using a wheelchair, or where a person can walk with assistance at the side.

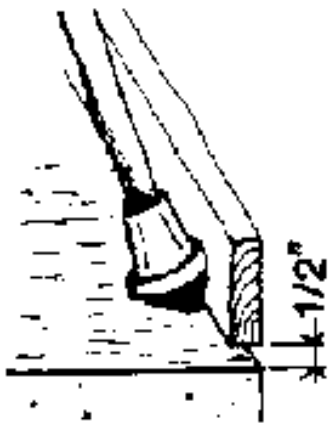

Surface height changes from the doorsill and top landing to the bottom landing shouldn't vary more than 1/2". Higher bumps can abruptly stop a wheelchair, or trip people walking, particularly those with an irregular gait.

All ramp runs and landings must be level from side to side. A cross slope (slope perpendicular to the direction of travel) can upset a person's balance and require more strength and

effort on the person's "downhill" side. Even the almost unnoticeable slope (1:96) built into public sidewalks to aid with water runoff can be tiring for a wheelchair user to negotiate.

It is advisable for ramps to have an "anti-slip" running surface; depending on local building code enforcement, this may be a requirement. On wooden ramps, treatments that are used include commercially available "grit" tapes, strips of rolled roofing or shingling, or laying down coats of polyurethane into which sand is sprinkled. For concrete ramps, the surface can be brushed with a broom before it hardens to create a rough texture.

**Safety Features:** Installation of safety features including handrails, guardrails, "crutch stops", guttering and sheltering should also be considered for a ramp building project.

Handrails should account for variables including a person's height, arm and hand strength, how the rails are used, and any local building code requirements that may apply. For example, standing users who lean on rails for support with arms extended often need a very different rail height than that used by persons propelling a wheelchair by pulling along the rails. 31 " to 34" is the typical height range, and the rails should be capable of supporting a 250 lb. load at any point along the length. The diameter should be no more than 1 1/2", and may need to be smaller for children or adults with impaired grip strength. The preferred material is wood. Metal piping is sometimes used, but may present a problem for exposed skin in the wintertime.

Guardrails and edging called "crutch stops" or "bump boards" are also good safety factors that keep users from slipping off the side of a ramp or landing. Guardrails are mounted along the structure's perimeter, usually at a seated person's knee height-18" to 20" or so. "Crutch stops" are curbing mounted on, or a few inches above, the surface of the structure's perimeter.

Two additional safety features to consider are guttering and sheltering. If not present, roof gutters may be advisable for ramps running close to a home to handle water runoff that may create slipping hazards. In cases where the person's mobility is severely restricted, some form of rampway sheltering may also need to be considered. Depending on site and home roofline, one strategy for ramps hugging a house is to build a small extension off the roof. Extending the ramp's posting vertically can provide support for the lower edge.

---

***Layout Issues:*** The three most common ramp layouts are:

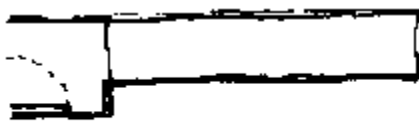

Straight or in-line

- "straight-shot"- landings and rampway in a straight line;

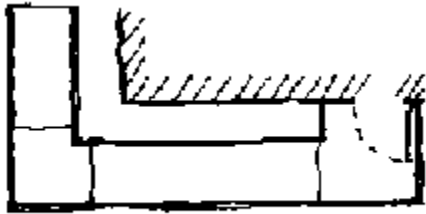

Dog-legged or L-shape

- "dog-legged" or "L-shaped"- ramp changes direction 90 degrees at an intermediate landing; can also be called a "wrap-around" when it hugs the house;

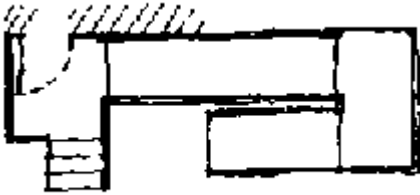

Switchback

- "switchback"- 180-degree change in direction between one run of rampway, an intermediate landing, and another run of rampway.

Generally, ramps follow a path of travel frequently used by all household members, such as from the kitchen to the garage or driveway. However, using a main pathway may create a problem for some households, making it advisable to locate the ramp at a lesser-traveled exit. In some situations, though, none of a home's exits provide a workable ramping option. In these cases it may be necessary to create a new exit. One possibility to consider is converting an existing window into a new doorway-the window area already may have some of the structural framing a doorway needs.

To incorporate a run of stairs off the top landing of the ramp is a good design feature to include, enabling other household members and visitors to enter/exit directly instead of having to use the rampway.

The visual impact of a ramp may be a factor to consider in choosing a layout. Straight ramp runs, particularly those that project directly out into a yard or are extremely long, may look unattractive, while those sited close to/around a house may have a more pleasant appearance. Landscaping (bushes and plants, timbers, etc.) and other finish details (e.g. skirting to mask the area below) can improve appearance as well. Is there a concern about security and "curbside" appearance? If so, locating the ramp to the side or back of a property may minimize the visual indication of a resident with a disability.

Locating the ramp to take advantage of southern exposure so the sun can help dry the surface or melt snow is another factor to keep in mind. Additionally, positioning that takes advantage of neighborhood/lot wind patterns may aid in clearing snow and leaves. There also may be locations near trees or bushes that should be avoided for the leaves or pods they drop.

Don't forget to give some thought to the impact a ramp's location will have on competing yard uses in the area. For example, running a ramp from a door straight through the back yard to the garage may be the most efficient and least costly layout. If this placement limits games and other recreation activities that frequently have gone on in this area, is the tradeoff acceptable? How about ease in mowing? Getting back and forth between a garden area over on one side and where tools are stored on the other?

**Ramp**

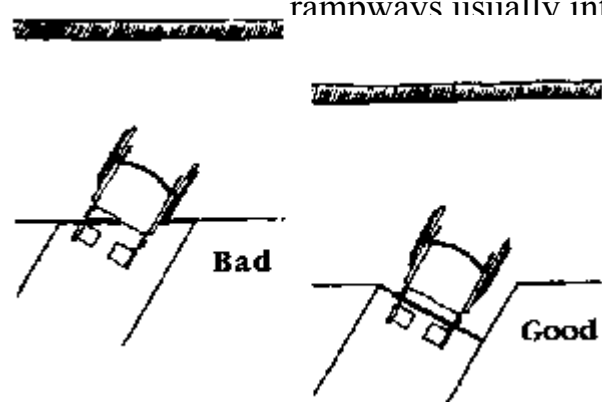

Most landings are designed as squares or rectangles, with ramnways usually intersecting them head-on. The resulting and inclined portion cut perpendicular vel. If a landing isn't square or rectangular, approaches a landing at other than head-on, t be given to making sure that the at and inclined portions still cut the path of travel. If they don't, and if hairs are involved, safety problems may r this has to do with the timing when each eels crosses over the boundary between the flat and inclined surfaces. When the two portions join head on, both wheels pass over the change in surface at the same time. However, if an angled intersection is present, one wheel crosses this boundary ahead of the other, resulting in an imbalance that could potentially cause a descending chair to tip.

**intersecting landing at an angle**

**Good**

**Angled landing**

Angled landings also require special attention. Seams between the flat and inclined portions in this type of construction similarly must join perpendicular to the direction of travel. When wheelchair users are involved, the landing additionally must provide enough

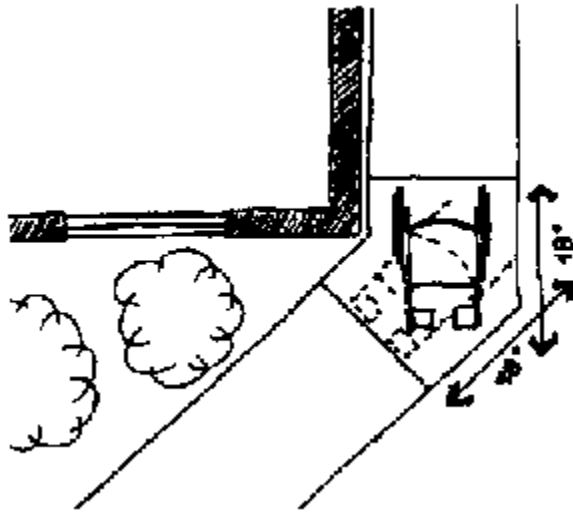

space for rolling onto the landing, turning slightly, and rolling off. This is usually about 48" in each direction of travel.

---

### Construction Methods

***Berming:*** Berming can be a good, economical, way to handle total rises that don't exceed about 18". The grade along the path of travel is built up with dirt or sand, then a walk is installed out of concrete, blacktop, patio blocks, or even treated wood decking. The yard can be finished as desired with new sod, reseeding, and plantings. By blending in with the house and yard, the "ramping" provided in this

manner is usually much less visible than a frame structure.

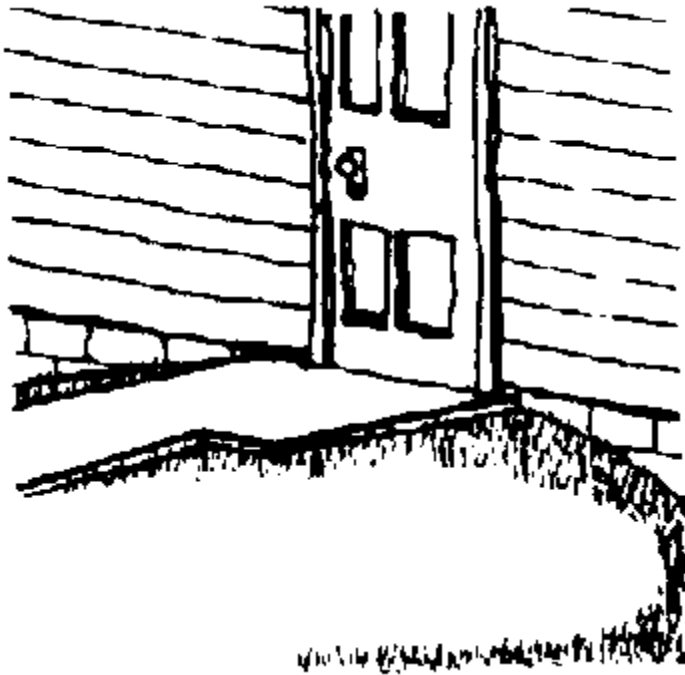

***Post-and-Beam:*** A majority of ramps built at homes are of the "post-and-beam" construction type. These structures are typically built with wooden framing, but metal framing is infrequently used. When wood is used, lumber should be of a species naturally resistant to decay (e.g. redwood or cedar), or treated with chemical preservatives.



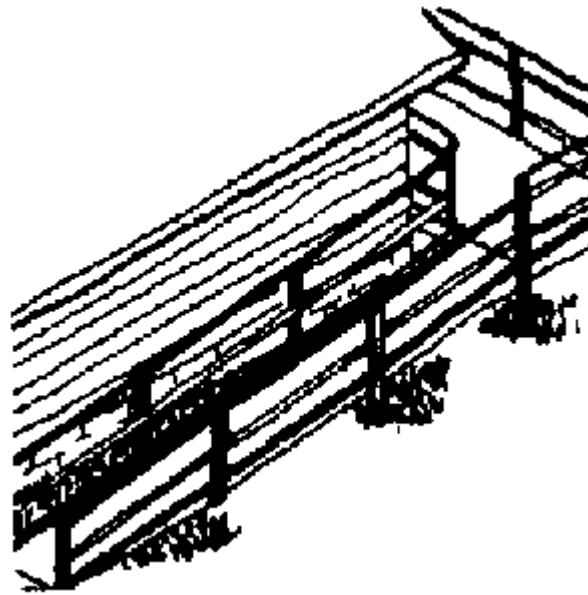

There are two common ways to install the posts. One is to sink timbers vertically into the ground below the frost line into holes filled with sand, gravel, or concrete. The other is to pour concrete into the hole and install an anchoring bracket on top into which the posts are bolted. Horizontal "beams" are then attached between posts to frame the perimeter for landings, and between rampway posts to create the running surface support. Finally, the "joists" providing support for landing and ramp surfaces are installed at right angle to the beams.

Post-and-beam rampway/landing surfacing is typically also installed out of wood, infrequently, out of metal grilling, or concrete over a corrugated metal or plywood base. When wood is used, the preferred method is to lay dimension lumber (e.g. 2" x 6"s ) perpendicular to the direction of travel, spaced with a slight gap (about 1/4 ") through which rain/snow/dirt can fall. Plywood is sometimes used, but problems develop because it can separate over time, and its surface can become very slippery with ice/rain. Indoor/outdoor carpeting is also sometimes installed, but similarly, it's not appropriate for ramps exposed to the weather because it can stretch over time, and collect/hold water.

A post-and-beam bottom landing may be created as a continuation of the surface decking (e.g. a "duckwalk"), or out of concrete. Specs for concrete are essentially the same as for a typical sidewalk-the pathway is excavated approximately 4", sand/wire mesh is laid to give a good foundation, then 3" to 4" of concrete is poured with expansion joints every 36" to 48".

Round, wood handrails may be installed, or 2"x4" lumber notched on one side to create a finger-hold area can also be mounted. Guardrails commonly are out of 2"x 4" lumber, crutch stops out of 1"x 2" lumber.

***Solid Construction:*** This type of ramping is typically built out of concrete, and while infrequently used at homes, is the most stable and probably most efficient for wider widths (e.g. 42" to 60"). It is constructed by erecting temporary forms (usually wooden), into which rubble (field stone, broken concrete blocks, bricks, etc.) and then concrete are poured to create the one-piece structure. Concrete ramp design is best done by masonry professionals, because of the possible need for reinforcing, expansion joints, and structural tie-in with the house.

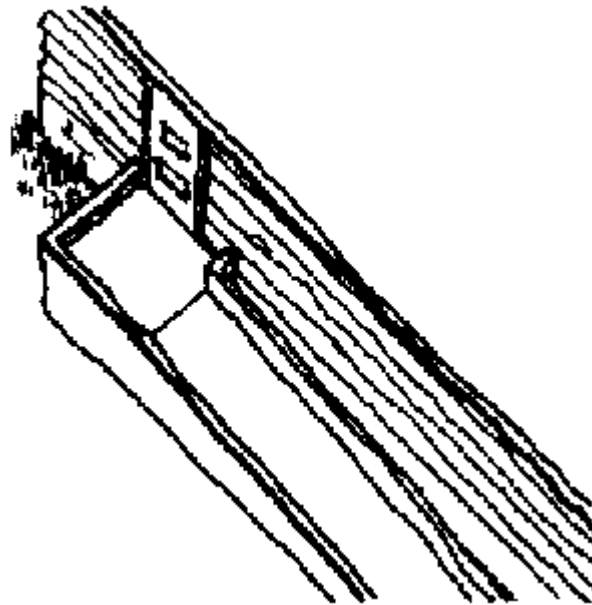

## ***Codes and Permits***

Is a building permit needed for your ramp building project?

**The only way to find out is to contact the building code office for your community.**

Telephone numbers are listed in the Government section of the phone book under Building Inspection or call the administrative office, and they will direct you.

When speaking with local building code officials, be sure to inform them if the

ramp will be temporary or permanent because this may have a bearing on whether or not a building permit is needed.

It is strongly advised that you work with the local officials because they can help you determine if a permit is needed, as well as with information regarding specific construction questions. If you do need a permit, it will be very helpful to have a site plan, elevation plan, framing plan, and estimated costs for the ramp. Information from this manual can be used in the application process. Be sure to take the engineering documentation with you for your plan review.

Ramp project personnel worked closely with local building officials and the Minnesota State Department of Administration during the design process to insure that the ramp design presented here is acceptable under Minnesota guidelines. Other states may differ in circumstances which may require variations in this design. Please check with your local officials before you begin a ramp.

## **INFORMATION YOU WILL NEED FOR A PERMIT**

- Site Plan:

  - A sketch of home and lot showing where lot lines are and where ramp will be placed. Indicate height, length and width of ramp.

- Determine Slope Ratio:

- Framing Plan:

  - A sketch of how your ramp will be built. It is helpful to copy pages from this manual to describe components.

- Engineering

- Estimated Cost

  - This is needed to determine the cost of permit.

- Photographs:

  - Although not required, they would be helpful when discussing your project with building officials.

## Sample Site Plan

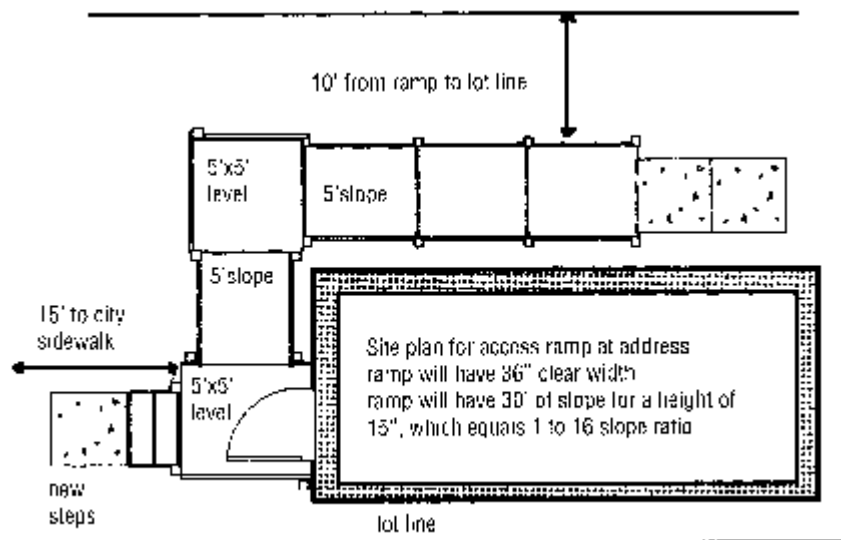

### More Permit Information

During your plan review, the building official may have an opinion regarding the slope at which your ramp should be built. While the Minnesota codes for public settings require a 1 to 20 slope for outside ramps, and various design codes recommend a 1 to 12 slope, private homes do not have to comply with those provisions. The slope of the ramp you are building should be determined by the needs of the user and a 1 to 20 slope may be appropriate. However, a shorter ramp with a slope anywhere between 1 to 12 and 1 to 20 may also be appropriate. You should be able to show that the slope you have chosen is both safe and convenient for the person using the ramp. If you wish to build a ramp that is steeper than 1 to 20 and the building official indicates that you cannot, you may wish to refer them to Chapter 1340.0200 Subp. 2. A.

This information has been distributed to building officials throughout Minnesota. Several building officials have provided ideas and assistance during the development of the Ramp Project. Local officials are available to review your ramp plans. They can help you build the best ramp possible to suit your needs.

PLEASE REMEMBER:

**SPECIFICATIONS FOR THIS MODULAR RAMP SHOULD NOT BE CHANGED...**

**The modular ramp design insures the strength and stability needed for safe use.**

**Changing or eliminating any of the components can reduce the structural integrity of the ramp and create dangerous situations**

**If you are building the ramp outside of Minnesota, be sure to check with your local building officials regarding this design and their requirements by law.**



**A review of the building code requirements for the modular wheelchair ramp.**

**A LETTER FROM  
THE STATE OF MINNESOTA,  
DEPARTMENT OF ADMINISTRATION,**

**BUILDING CODES AND STANDARDS DIVISION, SEPTEMBER 24,1992**

Building Permits: Uniform Building Code (UBC) section 301(b)7 exempts "platforms, walks and driveways not more than 30 inches above grade" from the requirement for a building permit. However, this section makes it clear that the work must still comply with the applicable provisions of the building code as well as any other laws or ordinances of the jurisdiction.

Land Use/Zoning Permits: Local government regulates land use through zoning codes. There may be restrictions on distance to property lines, maximum area and height, etc. Specific requirements will vary among jurisdictions so it is necessary that the appropriate local government department be contacted prior to beginning construction. Permits, including a site plan showing the location of the proposed ramp, may be required to verify compliance with zoning code provisions.

Guardrails: UBC 1711 states in part that open and glazed sides of stairways, landings and ramps, which are more than 30 inches above grade shall be protected by a guardrail. When a guardrail is required on a ramp or landing serving a single family dwelling, the guardrail must not be less than 36 inches high with intermediates spaced such that a sphere six\*\* inches in diameter cannot pass through. The dimensions must be on the plan when this requirement is applicable.

**\*\* As of March 20, 1995, the Minnesota State Building Code changed to require intermediates to be installed to prohibit passage of a 4" sphere**

Ramps: According to UBC 3307, ramps used as exits from the building shall comply with this section.

**Subpart (c)** states that: the slope of the ramp shall not be steeper than 1 vertical to 8 horizontal. The slope should be identified on the plans. **(Note: this vertical to horizontal slope is not recommended because it is too steep. Minimum recommended slope is 1-12).**

**Subpart (e)** states that when the slope of the ramp is steeper than 1 vertical to 15 horizontal, a handrail must be installed. The handrail must comply with Section 3306(j) and be mounted not less than 34 inches nor more than 38 inches above the ramp surface. The handrail must be dimensioned on the plan.

**Subpart (g)** states that the surface of the ramp shall be roughened or shall be of slip-resistant materials. This should be identified on the plan.

**Weather Exposure:** UBC 2516(c)11 requires that the members which form the structural supports be of approved treated wood (or of natural resistance to decay). It appears that this has been clearly covered in the plans.

**Footings:** UBC 2907(b) exception 1 permits a one-story wood building not over 400 square feet in area to be supported on a wood foundation plate when approved by the building official. In our opinion, the support of this ramp should be considered adequate provided that (1) the design engineer has accounted for anticipated frost and thaw action, (2) the ramp is secured to the house landing or threshold, and (3) wood in contact with the ground is pressure treated to at least .401bs/cu. ft. of retention.



**Other:** As long as these ramps serve only single family, R-3 occupancies, they are not required to comply with the requirements of Chapter 134O, Facilities for the Handicapped.

The completed plans for the ramp should include compliance with all applicable code provisions, the detailed specifications and the certification of the Minnesota registered engineer.

A handwritten signature in cursive script that reads "Scott D. McLellan".

Scott D. McLellan, Building Code Representative

---

Last year we built a ramp with the new system of support beam footings.

Our ramp hasn't shifted in the least. We have used it daily throughout all kinds of Minnesota weather without a problem. It was ideal for a residential setting and construction was relatively easy.

We organized a "ramping bee" and because we didn't need cement footings we were able to be more flexible in the construction and placement of the ramp."

-Gregory Knox-Carr

---

## *Ordering Materials*

### **Example ramp:**

Two level landings, each 58" x 98 1/2"; 29' of sloped surface required. Use two 116" modules and two 58" modules to obtain the needed length (other combinations are possible).

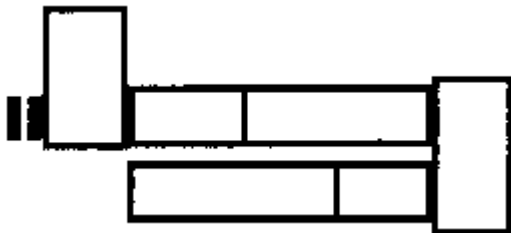

Draw an overhead view of the ramp and make several copies. On the first copy, determine the number of landings and modules needed. Begin a materials list, keep a separate page for each landing and module ordered so that during construction pieces can be matched to their intended purpose.

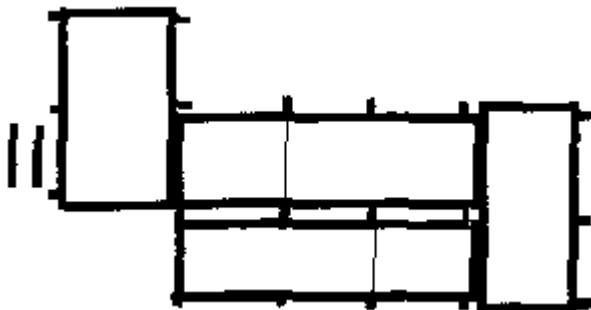

On the next copy of your overhead view, determine the number of support structure needed. You can estimate how long each 4x4 needs to be by adding 34" to the distance between the ramp surface and the ground for each post location. Remember that the legs of the support structures do not have to be equal in length. Also, if you are placing 4 x 4s in the ground for handrail support at the bottom of the ramp add at least 2' for each

sunken 4x4. Determine the 2 x 6s needed for the cross supports for the landings and modules. Add this material to your list.

Now determine if 2x4 diagonal bracing is needed, keeping in mind that diagonal bracing is needed when the top of the cross support is more than 21" off the ground, and that diagonal bracing is needed on each side of the 4x4 support posts. Also determine the number of gussets you will need and the number of 1'x 1' plywood pads needed for the base of the support posts (thirty-two 1'- square pads can be made from a 4x8 sheet of 3/4"-thick plywood).

Determine the number of 3/8" carriage bolts needed to connect modules and landings together (three per connection). To determine number of 1/2" carriage bolts, remember 4 x 4's with diagonal bracing require 10" bolts, 4 x 4's with gussets require 8" bolts, and 4 x 4's bolted to only one cross support require 6" bolts.

The next step is to determine the dimensions for the guardrail/ handrail. Decide if you are going to use plowed 2x6 for the top handrail or if you will have a 1 1/2"-round handrail.

On the overhead view of the ramp determine the lengths needed for the guardrail. You should have an equal number of 2 x 6s and 2 x 4's. Use the longest possible continuous 2x6 for your top railing. If you have a 15' long section of ramp, order 16' long boards. (Maintain a 4"-spacing between the spindles, ten 30"-long spindles per 59" run of ramp).

The last step is to determine lumber for steps or boardwalks that might be needed. You are now ready to combine all of the lumber needed onto to a materials order form. Keep the individual component sheets to refer to during construction. This will reduce the chance of using the wrong lumber for a particular component.

---

## **STATE SALES TAX LAW CHANGES**

(State of Minnesota)

Chair lifts, ramps, and elevators and building materials used to install or construct them are exempt from sales tax if a physician authorizes them and installed in or



attached to the owner's homestead.

Sales tax must be paid on the purchases and a claim for refund filed by the owner of the homestead property to obtain a refund of the sales tax paid. If tax was paid by a contractor, the home owner must file a claim for refund of sales tax paid by the contractor including sufficient information to verify the amount of sales tax paid on the project. Contractors are required to furnish a statement to the home owner for material costs and taxes paid.

This exemption is effective for sales after January 1, 1990.

---

## MATERIALS ORDER FORM

### TREATED LUMBER

\_\_\_\_\_ 3/4 Treated Plywood

\_\_\_\_\_ 5/4x6x8 Decking

\_\_\_\_\_ 5/4x6x10 Decking

\_\_\_\_\_ 5/4x6x14 Decking

### Bolts

\_\_\_\_\_ 2x2x8 Baluster Spindle

\_\_\_\_\_ 2x4x8 Treated

\_\_\_\_\_ 2x4x10 Treated

### Bolts

\_\_\_\_\_ 2x4x12 Treated

\_\_\_\_\_ 2x4x14 Treated

\_\_\_\_\_ 2x4x16 Treated

\_\_\_\_\_ 2x6x8 Treated

\_\_\_\_\_ 2x6x10 Treated

Screws \_\_\_\_\_ 2x6x12 Treated

### Deck Screws

\_\_\_\_\_ 2x6x14 Treated

### HARDWARE

\_\_\_\_\_ 2x6 Joist Hanger

\_\_\_\_\_ 2x4 Joist Hanger

\_\_\_\_\_ Hanger Nails

\_\_\_\_\_ 3/8x4 Carriage

\_\_\_\_\_ 3/8 Hex Nuts

\_\_\_\_\_ 3/8 Washers

\_\_\_\_\_ 1/2x6 Carriage

\_\_\_\_\_ 1/2x8 Carriage

\_\_\_\_\_ 1/2x10 Carriage

\_\_\_\_\_ 1/2 Hex Nuts

\_\_\_\_\_ 1/2 Washers

\_\_\_\_\_ 2.5" Galv Deck

\_\_\_\_\_ 3" Galv

\_\_\_\_\_ Handrail Bracket

_____ 2x6x16 Treated	_____ 1.5" Handrail
_____ 4x4x8 Treated	_____ Other
_____ 4x4x10 Treated	_____
_____ 4x4x12 Treated	_____
_____ 2 Step Stringer	
_____ 3 Step Stringer	
_____ 4 Step Stringer	
_____ 5 Step Stringer	

Date Order: \_\_\_\_\_

Ship To: \_\_\_\_\_  
 \_\_\_\_\_  
 \_\_\_\_\_

### ***Building Process***

The process used in building a modular ramp involves creating a level landing at the doorway and then attaching the sections one after another until the end point is reached. Because slope adjustments may be needed during construction, it is wise to attach sections temporarily and insure that the slope is correct before bolting, adding trimmers and the bracing. Adding guardrail and handrail is the final task. Steps can be added to the landing after it is completely supported. Standardized components allow the units to be easily recycled and used at other locations. The ramps are designed for easy disassembly and may be used more than once.

1. Notch 2 x 6s used to create level landing at door.
2. The first module in place, level landing established, bumper jack is being used for temporary positioning.
3. Landings are level, and slopes are correct.
4. Trimmers and gussets are permanently attached after slope is correct and 4 x 4s vertical.

5. Attach 2 x 6s and 2 x 4's to 4 x 4s.
6. Guardrails are the last step to complete the ramp.

It is helpful to have copies of these following construction pages available at the ramp site.

**To make ramp with 36" clear space make modules 39" wide.**

Ramp and landing modules are designed to use 10 pieces of decking for each 58" length, to insure proper gaps between decking.

Standard length modules make reuse easier. If a nonstandard length is needed for a particular ramp, build the length you need using these guidelines

### **58"-long x 42"-wide Ramping Module**

(for ramp with 39" clear width)

#### **Components:**

- 4** 2x6 by 55" Joists (Order two 2x6x10 and cut 4 joists)
- 2** 2x6 by 42" End Pieces (Order one 2x6x8 and cut 2 end pieces)
- 10** 5/4" x 6" by 428 Decking (Order 14' decking and cut 4 pieces from each.. Two and one-half 14' decking equal ten 42" pieces.)
- 80** 2 1/2" Deck Screws (8 per Decking Plank)
- 16** 3" Deck Screws (To attach end pieces to joists)
- 8** 2x6 Joist Hangers
- 64** Joist Hanger Nails (8 per Hanger)

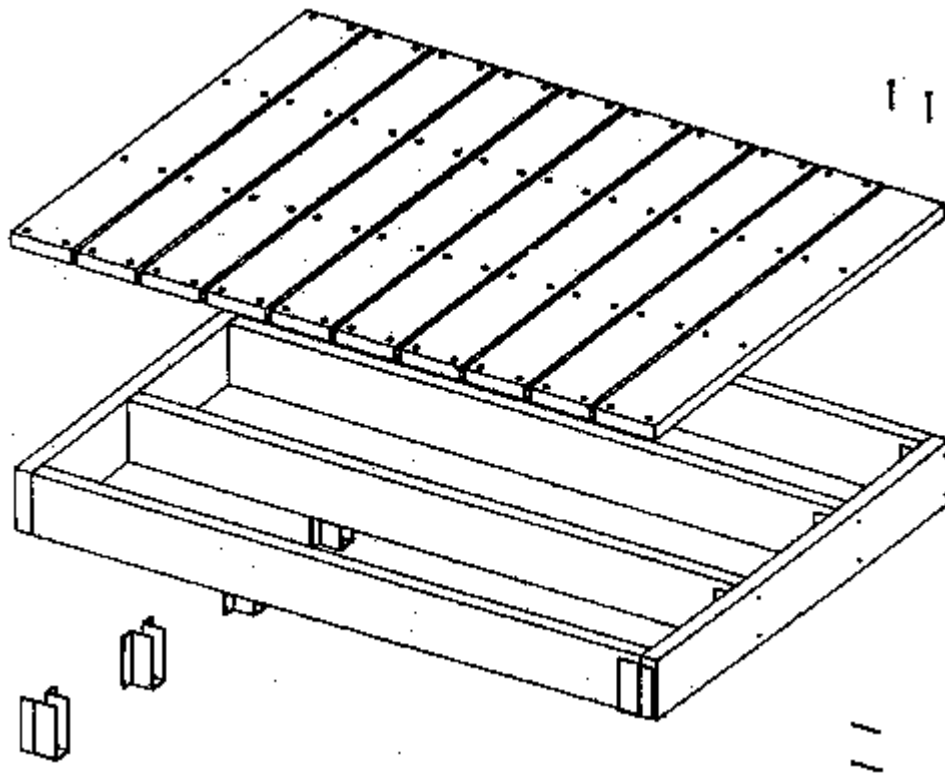

### Construction Notes:

1. Cut joists and end pieces to length and assemble on flat surface. Space joists 14" apart on center.
2. Screw end pieces to the ends of joists with 3" screws.
3. Insure module is square and nail on joist hangers.
4. Bend outside flange of four corner joist hangers flat against end pieces of module.
5. Decking may be attached at this point or after module frame is placed in a ramp. Decking adds significant weight to module. If decking added, you will need to remove decking end pieces when assembling ramp.
6. Drill a 3/8" hole centered on the end pieces and drill two 3/8" holes 6" from each side. All three holes to be centered vertically on the end piece.

### 116"-long x 42"-wide Ramping Module

Can be used to replace two 58" modules

## Components:

- 4 2x6 by 113" Joists (Order four 2x6x10 and cut 4 joists)
- 2 2x6 by 42" End Pieces (Order one 2x6x8 and cut 2 end pieces)
- 20 5/4" x 6" by 42" Decking (Order 14' decking and cut 4 pieces from each. Five 14' decking equals twenty 42" pieces.)
- 160 2 1/2" Deck Screws (8 per Decking Plank)
- 6 3" Deck Screws (To attach end pieces to joists)
- 8 2x6 Joist Hangers
- 64 Joist Hanger Nails (8 per hanger)
- 3 2x6 Blocking at mid-point of module (To maintain width and add stability)
- 12 3" Deck Screws for blocking

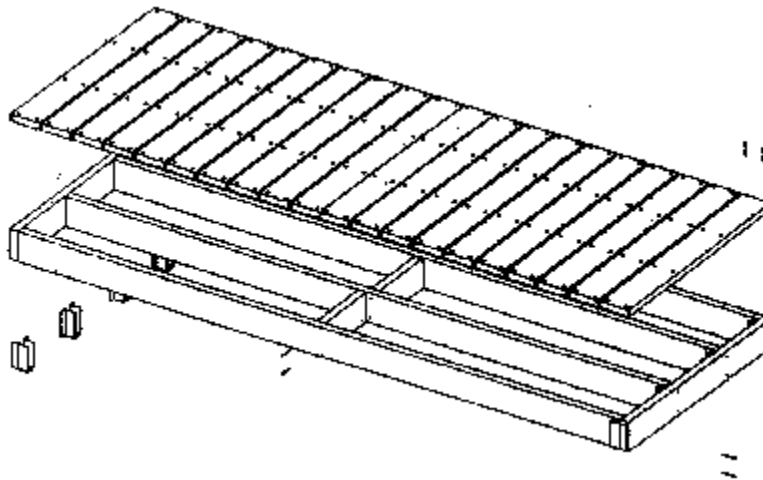

## Construction Notes:

1. Cut joists and end pieces to length and assemble on flat surface. Space joists 14" apart on center.
2. Screw end pieces to the ends of joists with 3" screws.
3. Insure module is square and nail on joist hangers.
4. Bend outside flange of four corner joist hangers flat against end pieces of module.
5. Screw blocking in place. Blocking maintains 42"-width of module and adds stability to module.
6. Decking may be attached at this point or after module frame is placed in a ramp. Decking adds significant weight to module. If decking added, you will need to remove decking end pieces when assembling ramp.

7. Drill a 3/8" hole centered on the end pieces and drill two 3/8" holes 6" from each side. All three holes to be centered vertically on the end piece.

## Choosing the width of your ramp

Proper width of the ramp is important for the person using the ramp. A minimum of 36" of clearance is needed and sometimes wider widths are advisable. The ramp modules can be made to the width that best meet the users needs. 39" and 42" wide modules have been described. If a wider ramp is desired, such as 48" wide, you need to adjust the materials ordered

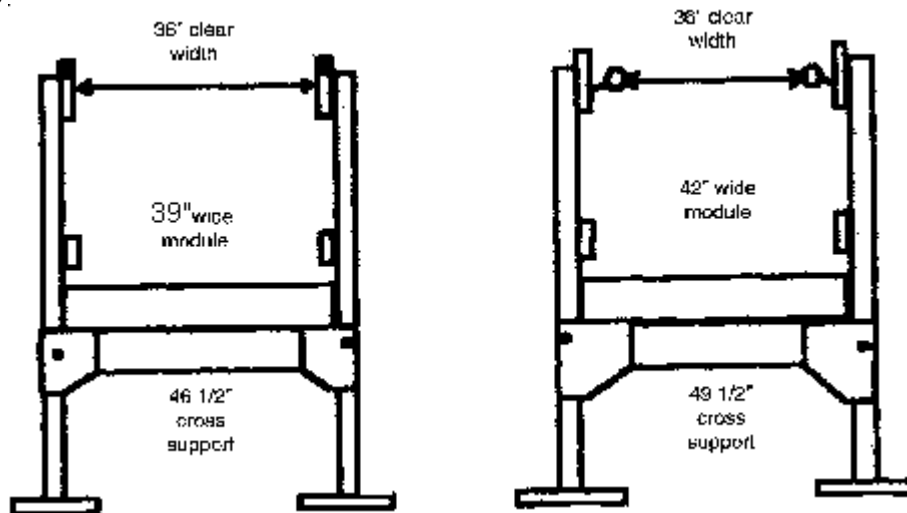

## 58"-long x 60"-wide Landing Module

Used for level landings in right-angle ramps and sometimes at doorway.

### Components:

- 5 2x6 by 55" Joists (Order three 2x6x10 and cut five joists)
- 2 2x6 by 60" End Pieces (Order one 2x6x10 and cut two end pieces)
- 10 5/4x6 by 60" Decking (Order five 5/4x6 by 10 and cut ten pieces)
- 100 2 1/2" Deck Screws (10 per decking plank)
- 20 2 1/2" Deck Screws (to attach end pieces to joists)
- 10 2x6 Joist Hangers

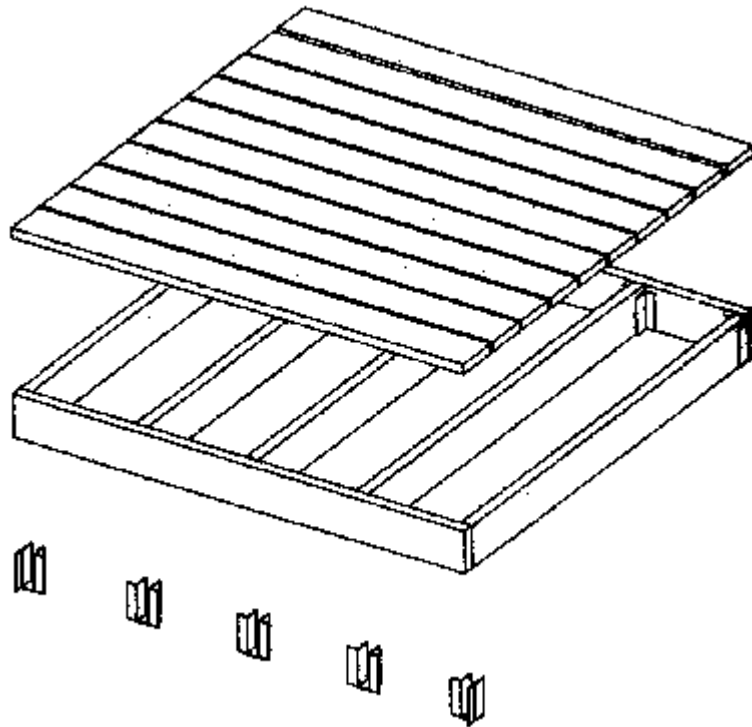

**Construction Notes:**

1. Cut joists and end pieces to length and assemble on flat surface. Space joists 15" apart on center.
2. Screw end pieces to the ends of joists with 3" screws.
3. Insure landing is square and nail on joist hangers.
4. Bend outside flange of four corner joist hangers flat against end pieces of landing.
5. Decking may be attached at this point or after landing frame is placed in a ramp. Decking adds significant weight to landing. If decking added, you will need to remove decking end pieces when assembling ramp.
6. 3/8" holes to allow connection to ramp modules will be drilled at time of ramp construction.

**58"-long x 98 1/2"-wide Landing Module (for 42" modules)**

**(use 92 1/2" wide module if using 39" ramping modules)**

**Used for level landings in 180-degree switchback ramps and sometimes at doorway**

## Components:

- 7 2x6 by 55" Joists (Order four 2x6x10 and cut seven joists)
- 2 2x6 by 98 1/2" End Pieces  
(Order two 2x6x10 and cut two endpieces)
- 10 5/4x6 by 98 1/2" Decking  
(Order ten 5/4x6 by 10 and cut ten pieces)
- 140 2 1/2" Deck Screws (10 per decking plank)
- 28 2 1/2" Deck Screws (to attach end pieces to joists)
- 14 2x6 Joist Hangers
- 112 Joist Hanger Nails

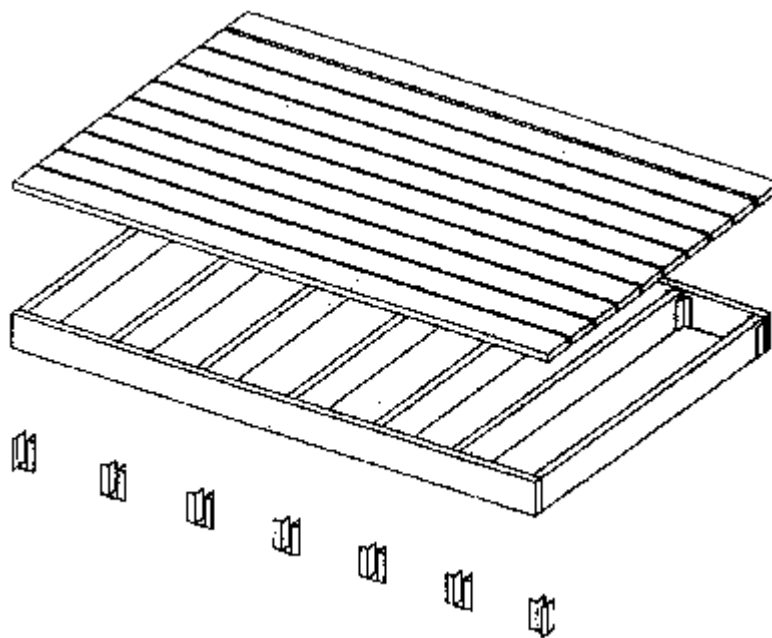

## Construction Notes:

1. Cut joists and end pieces to length and assemble on flat surface. Space joists 16" apart on center.
2. Screw end pieces to the ends of joists with 3" screws.
3. Insure landing is square and nail on joist hangers.
4. Bend outside flange of four corner joist hangers flat against end pieces of landing.
5. Decking may be attached at this point or after landing frame is placed in a ramp. Decking adds significant weight to landing. If decking added, you will need to remove decking end pieces when assembling ramp.



6. 3/8" holes to allow connection to ramp modules will be drilled at time of ramp construction.

**58"-long x 98 1/2"-wide Landing Module (for 42" modules)**

**(use 92 1/2" wide module if using 39" ramping modules)**

**Used for level landings in 180-degree switchback ramps and sometimes at doorway**

**Components:**

- 7 2x6 by 55" Joists (Order four 2x6x10 and cut seven joists)
- 2 2x6 by 98 1/2" End Pieces  
(Order two 2x6x10 and cut two endpieces)
- 10 5/4x6 by 98 1/2" Decking  
(Order ten 5/4x6 by 10 and cut ten pieces)
- 140 2 1/2" Deck Screws (10 per decking plank)
- 28 2 1/2" Deck Screws (to attach end pieces to joists)
- 14 2x6 Joist Hangers
- 112 Joist Hanger Nails

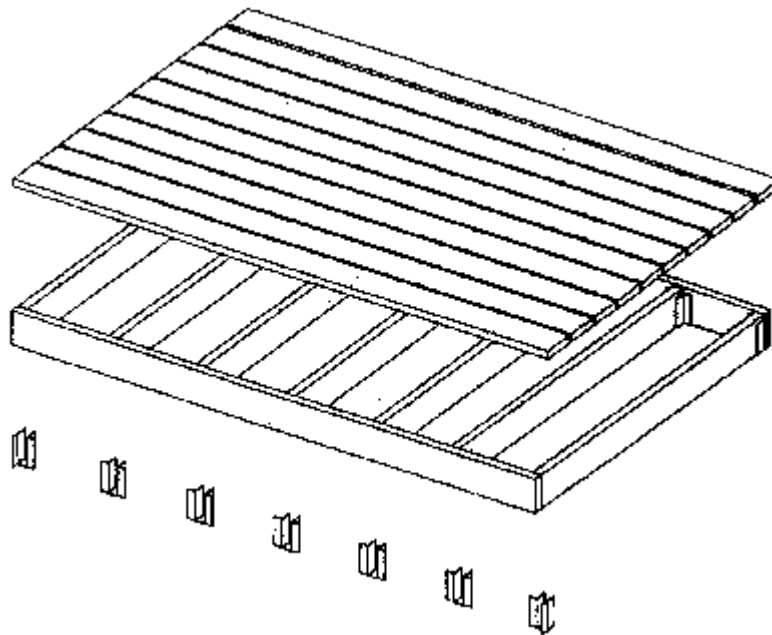

**Construction Notes:**

1. Cut joists and end pieces to length and assemble on flat surface. Space joists 16" apart on center.
2. Screw end pieces to the ends of joists with 3" screws.
3. Insure landing is square and nail on joist hangers.
4. Bend outside flange of four corner joist hangers flat against end pieces of landing.
5. Decking may be attached at this point or after landing frame is placed in a ramp. Decking adds significant weight to landing. If decking added, you will need to remove decking end pieces when assembling ramp.
6. 3/8" holes to allow connection to ramp modules will be drilled at time of ramp construction.

### **Tall Support Structure (for 42" modules)**

Used when distance between top of cross support and plywood pad exceeds 21"

#### **Components:**

- 2 4x4 Support Posts (Length determined by height requirements of ramp)
- 2 1'x 1' by 3/4" Treated Plywood Pads (Will be screwed to bottom of 4x4 with three 3" deck screws)
- 2 2x6 by 49 1/2" Cross Supports (Beveled to match slope of ramp) use 46 1/2" cross supports for 39" module
- 4 2x4 Trimmers (Length equals distance between bottom of cross support and plywood pad.) (Trimmers will be screwed to 4x4.)
- 2 2x4 Diagonal Braces (Length will be determined by height of cross support)
- 4 1/2" x 10" Carriage Bolts with nuts and washers (9/16" holes will be drilled in support structures for these bolts)

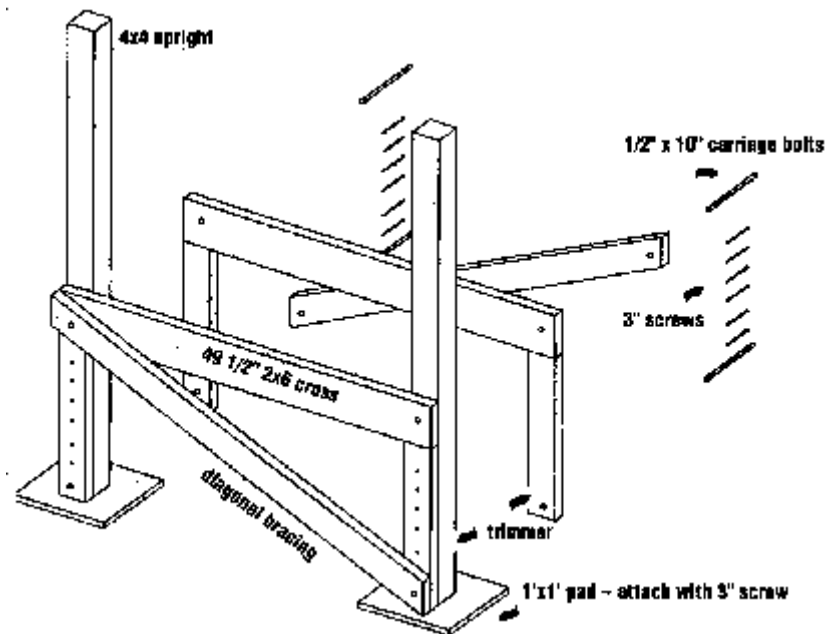

### Construction Notes:

1. During construction, determine the length of the 4 x 4s by measuring from a string line that equals the height and slope of the ramp you are building.
2. A standard guardrail height of 36" can be obtained by having 34" of 4x4 extend above the ramp surface. Compute the length of each 4x4 upright by measuring down from ramp surface to plywood pad on the ground and add 34" to that number.
3. The two legs are often not the same length due to uneven terrain.
4. The cross supports are an extra 1/2" long to allow space to easily set modules in place.
5. During construction, be sure that 4 x 4s are plumb and cross supports are horizontal before installing carriage bolts, trimmers, gussets and bracing. Temporarily attach cross supports with screws to allow for adjustments and place bolts, bracing and gussets after all modules are in place.

### Shorter Support Structure (for 42" modules)

Used when distance between top of cross support and 1'x1' x 3/4" pad is 12" to 21"

### Components:

- 2 4x4 Support Posts (Length determined by height requirements of ramp)
- 2 1'x 1' by 3/4" Treated Plywood Pads (Will be screwed to bottom of 4x4 with three 3" deck screws)
- 2 2x6 by 49 1/2" Cross Supports (Beveled to match slope of ramp)
  - use 46 1/2" cross supports for 39" module
- 4 2x4 Trimmers (Length equals distance between bottom of cross support and plywood pad.) (Trimmers will be screwed to 4x4.)
- 4 3/4"-thick Treated Plywood Gussets (see drawing for dimensions)
  - (Gussets will be screwed to trimmer and cross supports with seven screws per gusset.)
- 2 1/2" x 8" Carriage Bolts with nuts and washers (9/16" holes will be drilled in support structures for these bolts)

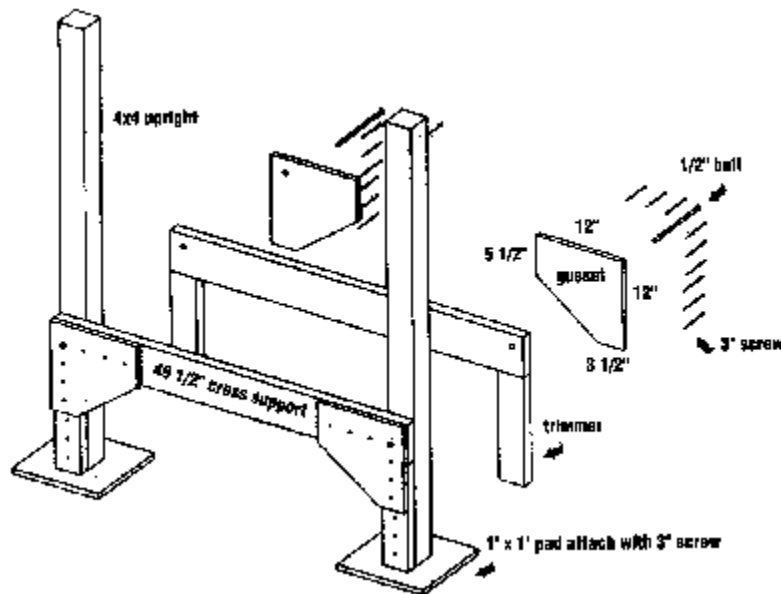

**Construction Notes:**

1. During construction, determine the length of the 4 x 4s by measuring from a string line that equals the height and slope of the ramp you are building.
2. A standard guardrail height of 36" can be obtained by having 34" of 4x4 extend above the: ramp surface. Compute the length of each 4x4 upright by measuring

down from ramp surface to plywood pad on the ground and add 34" to that number.

3. The two legs are often not the same length due to uneven terrain.
4. The cross supports are an extra 1/2" long to allow space to easily set modules in place.
5. During construction, be sure that 4 x 4s are plumb and cross supports are horizontal before installing carriage bolts, trimmers, gussets and bracing. Temporarily attach cross supports with screws to allow for adjustments and place bolts, bracing and gussets after all modules are in place.

### **Onsite construction assembly procedures**

#### **Straight, right-angle and switch-back layouts are shown.**

For illustrative purposes, a 58" x 7'11" level landing is shown at the doorway. The first sloped section is the same on all three ramps (much of the construction for all three styles is identical). All ramps have twenty-nine feet of sloped surface and could be made with 58" length modules, combinations of 116" and 58" modules.

The design of the level landing at the doorway is critical to the functional use and construction of the ramp. Because of the wide variety of existing stoops and entryway configurations, it is not possible to design a modular component that will meet the needs of all entry ways. Usually construction of the level landing requires customization on-site. Keep in mind the space requirements for use of the doorway and the requirements of the other users of the doorway . Steps will often need to be built to the new landing to replace the old steps covered. Steps are probably the hardest component to build. Experienced builders should handle that task. Before beginning construction, be sure to review the design principles listed in this manual as a final check. It is easier to change the design before construction than after construction.

- Place landing module so that 2x6 joists are 1 3/4" below bottom of door (when decking is added you will have 1/2" door clearance). Insure that the landing is level (temporary support with bumper jacks is helpful in leveling landing).
- Place pads as shown in drawing then measure from top of landing including decking to each pad. Add 34" to this measurement and cut 4 x 4's to this length.
- Attach pads to 4 x 4's with screws and place in position, insure they are plumb. Attach cross supports with screws temporarily. Be sure cross supports fit snugly under landing and that landing is level.

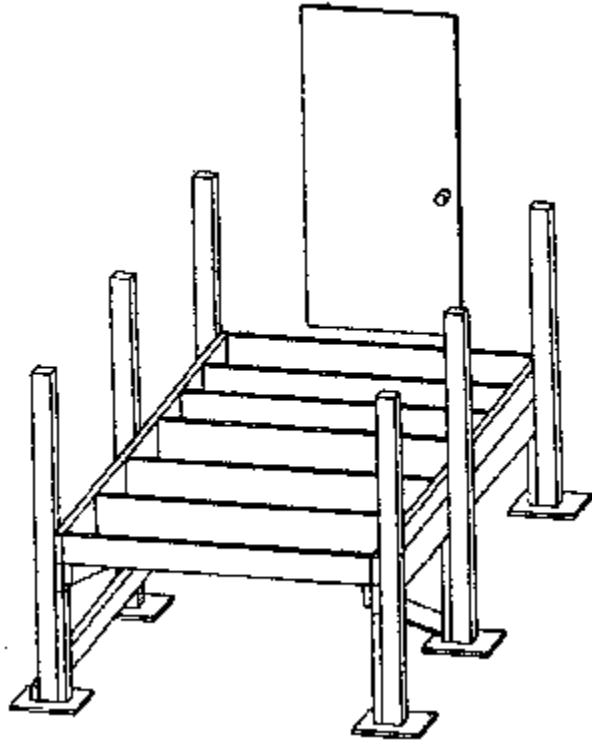

## **TO DETERMINE SLOPE OF THE RAMP**

### **(for ramp example shown)**

Run a 14'6" string line from top landing to where next level landing will begin. This line represents 1/2 of total vertical drop. Use a line level to determine horizontal height from top landing and measure 14 1/2" down. Bottom end of string line should be supported to this height. You will match the slope of the modules to this line.

Remember that decking adds 1 1/4" to the vertical measurement. If you place a piece of decking on the landing where the string line starts, be sure to use decking for the entire run of the ramp.

## TO HANG MODULES:

- Drill 3/8" holes in landing to match the 3/8" holes pre-drilled in Module 1.
- Place 3/8"x 4" carriage bolts in the holes in the landing, slide module onto bolts. Support lower end of module to approximate height of string line, add washers & nuts, and tighten (do not over-tighten as this will pull end piece away from lower module).
- Match module slope to string line and insure module is level side-to-side. Temporary support with bumper jacks is helpful in adjusting heights.

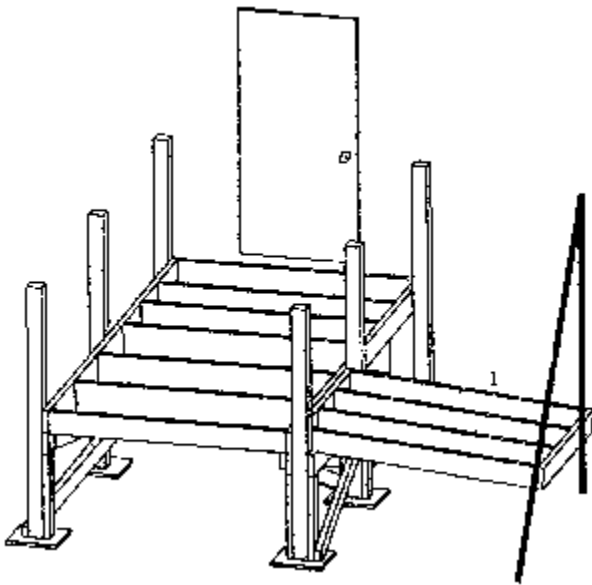

- Place 1'x1' pads beneath module corners and measure to top of module. Add 34" and cut 4 x 4s to this length.

- Attach pads to 4 x 4's and stand in place at lower end of Module #1. Insure that 4 x 4's are plumb, and module is level horizontally and at proper slope (by matching to string line).

- Attach beveled cross support with screws to each 4x4 at lower end of Module #1. This will hold cross support temporarily. Trimmers and bolts will be applied at lower end of Module #1 after all modules are in place.
- At upper end of module, place beveled cross support tightly beneath module and

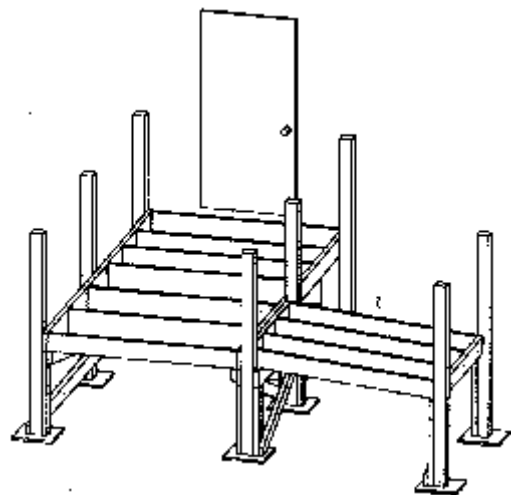

screw in place. Insure 4 x 4's are plumb.

**NOTE: Modules 1, 2, and 3 could be replaced with a 58" and a 116" module.**

- The cross support structures will always be 58" apart. When constructing the ramp, you will place the first support structure at the lower end of the first complete module you are working with and add remaining support structures later if the first module is 116".
- Attach Module #2 to Module #1 with 3/8" bolts and tighten firmly. Support lower end of Module #2 with jacks and match slope to string line. Cut 4 x 4s to length, stand in place at lower end of Module #2, and attach cross supports with screws.
- At top of Module #2, attach cross support to 4 x 4's with screws..
- Repeat process to add Module #3.
- The level landing is erected in the same manner as the sloped modules. In this example, a level landing is shown because it is recommended that ramps 29' or more in length have a level resting place.

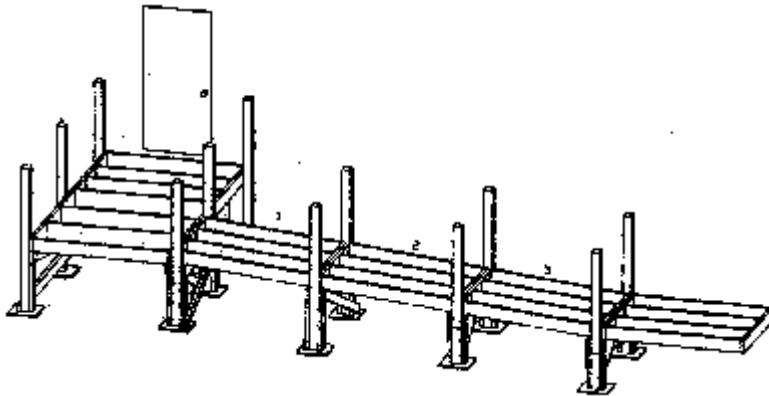

### Completion of Straight Ramp

**Note: Place string line from end of level landing to point where ramp will end in order to determine proper ramp slope.**

- Continue hanging modules and note that no gusset is needed between Modules #4 and #5. You will need to use 2x4 cross supports at the junction of #4 and #5.



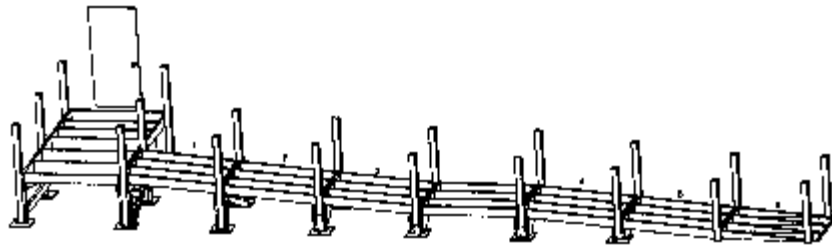

- Gussets are placed after the 1/2" carriage bolts have been inserted and tightened. A 1 1/2" hole is drilled to allow the threaded end of the bolt to pass through the gusset. A 1 1/2" indentation is made in the other gusset for the head of the carriage bolt.
- When all landings and modules are in place, make any adjustments needed to insure the slopes of each section are equal. Install the trimmers, 1/2" carriage bolts, bracing and gussets again making sure that 4 x 4s are vertical and ramp surface is level.
- Decking can now be installed. Use 10 5/4x6 pieces of decking for every 58" of landing and slope. Due to variations in the size of decking due to moisture content, it is important to lay all 10 boards in place and make sure the gaps between them are equal. Equally spaced gaps are needed for good drainage. "Wet" decking boards will shrink a little to create proper spacing.

**Check the end grain of each decking piece. Attach to joist so that the grain is facing down like a rainbow.**

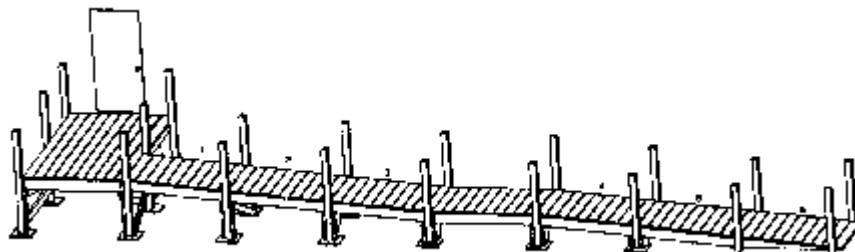

## TRANSITION FROM RAMP TO GROUND

### Option A:

Working over dirt, remove enough dirt to allow modules #5 and #6 to maintain the proper slope for a smooth transition to ground level. A 42"-long 2x6 is laid underneath the end of Module #6, and another under the junction of Modules #5 and #6. The lower two sets of 4 x 4's are set into the ground to a depth of 24".

The newly cut end of any piece of treated lumber that will be in ground contact should be protected with a fence post preservative type of product. Uncut ends do not need extra protection. Consult with the lumberyard where you purchased the lumber for advice on specific products.

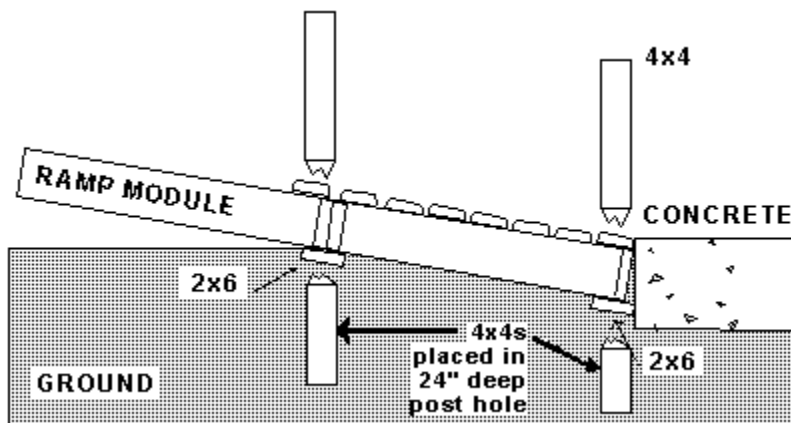

## TRANSITION FROM RAMP TO GROUND

### Option B:

Working over concrete, blacktop, or frozen ground, four 1 1/2" joists are cut to a taper that matches the ground level. An end piece is attached to these four joists, and this is bolted into place in the same manner as the module (this replaces Modules #5 and #6). An outrigger is placed underneath this section where the junction of Modules #5 and #6 would be. The 4x4 post is braced using this outrigger.

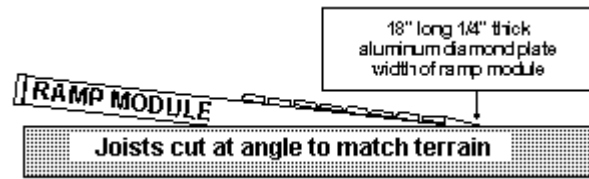

**Aluminum diamond plate is skid resistant and provides a smooth transition from end of ramp to a hard surface. Attach the last piece of decking with four 1 1/4" flat head screws. Masonry screws can be used to attach plate to concrete.**

- To construct outrigger, cut a 1 1/2" x 3 1/2" notch in each outside joist where the junction of Modules #5 and #6 would be. Place a 26" long 2x4 through this notch and attach to inside joist. Stand 4x4 in place and cut a 15" long brace with a 45-degree angle cut on each end using 4 x 4's. Attach this brace with screws to the upright 4x4 and the horizontal 2x4.

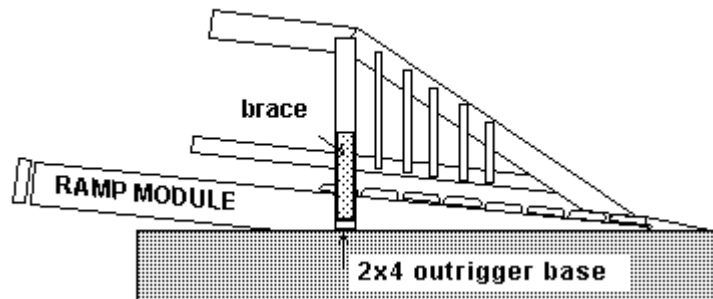
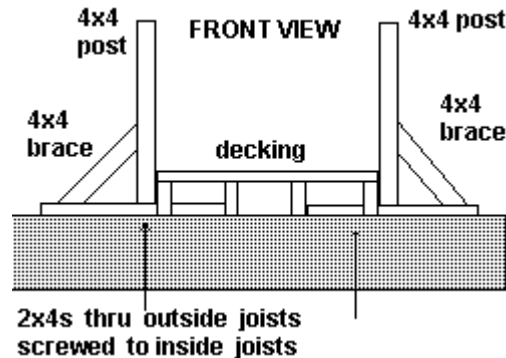

- Upper guardrail will be angled to the end of ramp and toe nailed in place. Lower guardrail will be toe nailed into upper guard rail.

## CUTTING TAPERED JOIST NEEDED FOR OPTION B

Assemble one end piece of a module, **NAILING HANGERS TO THE END PIECE ONLY**. Place this end piece on top of ramp module as shown above and set a joist into each hanger making sure all 4 are parallel. The opposite end of the joist will rest on the ground. If the surface under the joist is uneven, try to level as much as possible. Place the 2x6 marking guide beside each joist and draw a pencil line from A to B. Remove each joist and cut along the pencil line. Bolt the end piece to the upper ramp module.

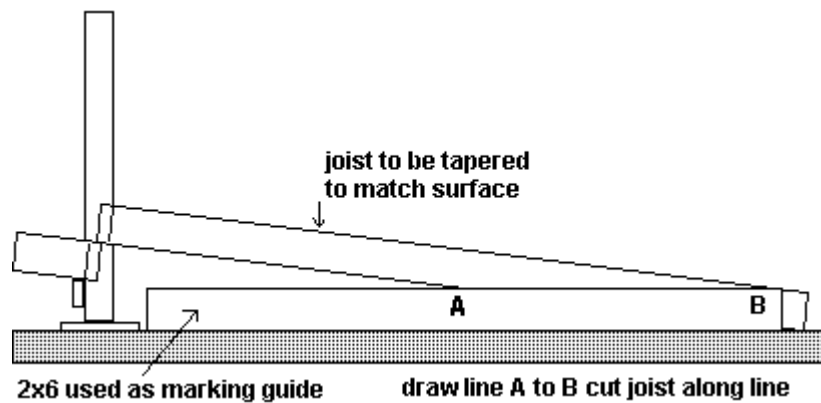

Place tapered joist back in the hangers and install hanger nails into the two middle joists. You will be cutting a notch in the outside joists for the outrigger, so do not attach them to joist hangers until the outriggers are completed. Proceed as described above (page 33A).

## BOARDWALK TO CREATE HARD SURFACE FOR WALKING AND WHEELING

Landscaping fabric can be placed under the boardwalk to prevent plant growth between the decking boards.

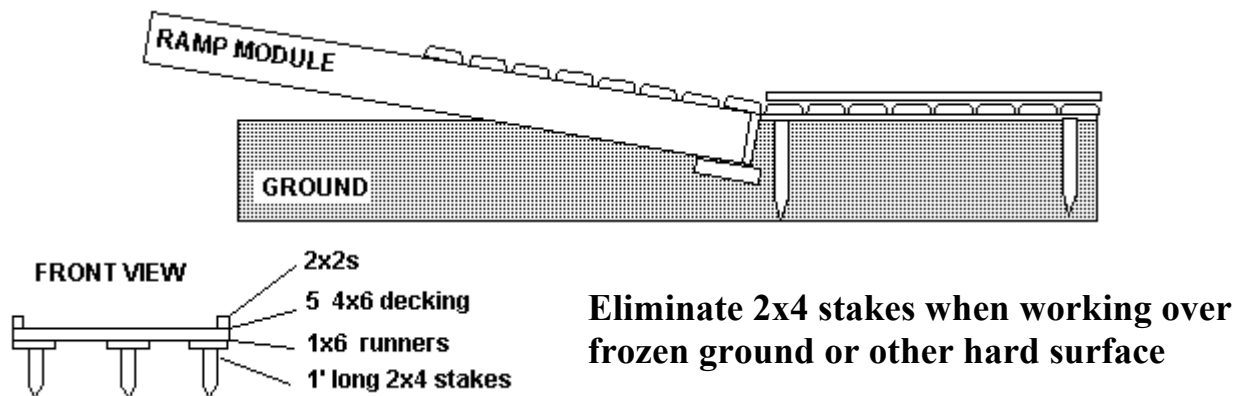

Boardwalk, leading from ramp to driveways or sidewalks, can be installed instead of concrete or asphalt walkways. Three 1 x 6 treated boards are staked to the ground with

1' long 2x4 stakes at 5' intervals. Decking boards are then attached to the three parallel runners. 2 x 2's can be screwed in place on each outside edge to act as a wheel guard. Any length boardwalk can easily be installed, with turns as needed. Boardwalk, like modular ramps and stairs, can be used as long as needed and then easily removed.

The newly cut end of any piece of treated lumber that will be in ground contact should be protected with a fence post preservative type of product. Uncut ends do not need extra protection. Consult with the lumberyard where you purchased the lumber for advice on specific products.

## GUARDRAIL/HANDRAIL

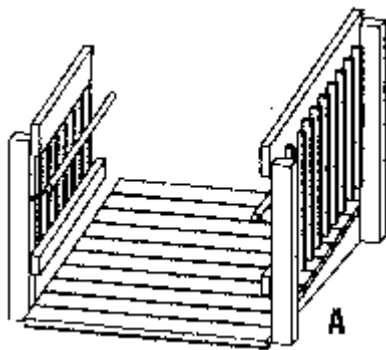

**Option A:** Attach 2x4 boards to 4 x 4's parallel to ramp surface, 4" above ramp surface. Attach 2x6 boards parallel to 2 x 4's so that top of 2x6 is 36" above ramp. Cut 2x2 spindles to 30" lengths and attach vertically to 2x4 and 2 x 6's with 4" space between each. Use a 3 7/8" spacer to make spindles installation easier. 1 1/2" round hand rail can be attached to the 4 x 4's or the 2x6 at a height that is most convenient to the user. (The reason the 2x4 is placed 4" above the ramp is to allow for easier snow removal.)

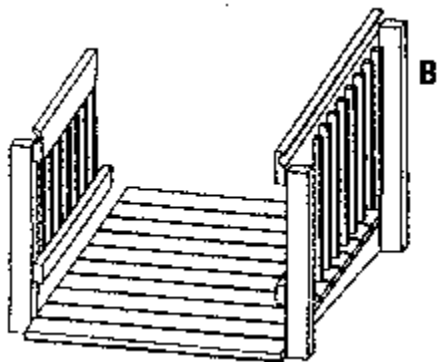

**Option B:** Same as above, except that top rail consists of 2x6 board that has been plowed for a hand grip. The plowed groove is placed on the outside of the ramp.

When ordering lumber for guardrail, order the longest board possible; i.e. 15' of guardrail from 2x6x16. You can get 3, 30" spindles from an 8' length and you need 10 spindles per 59" section.

Note: The 30" 2x2 spindles can be cut with a 30 degree bevel on one end and installed as shown at right.

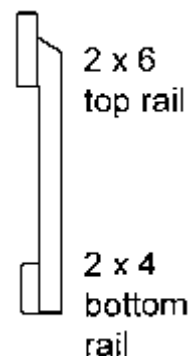

**Note: Type of guardrail/handrail selection is based on needs of the user. It may be easier for someone to pull themselves up the ramp using the 1 1/2" round handrail rather than using the plowed-style of 2 x 6 handrail.**

## **COMPLETED STRAIGHT RAMP**

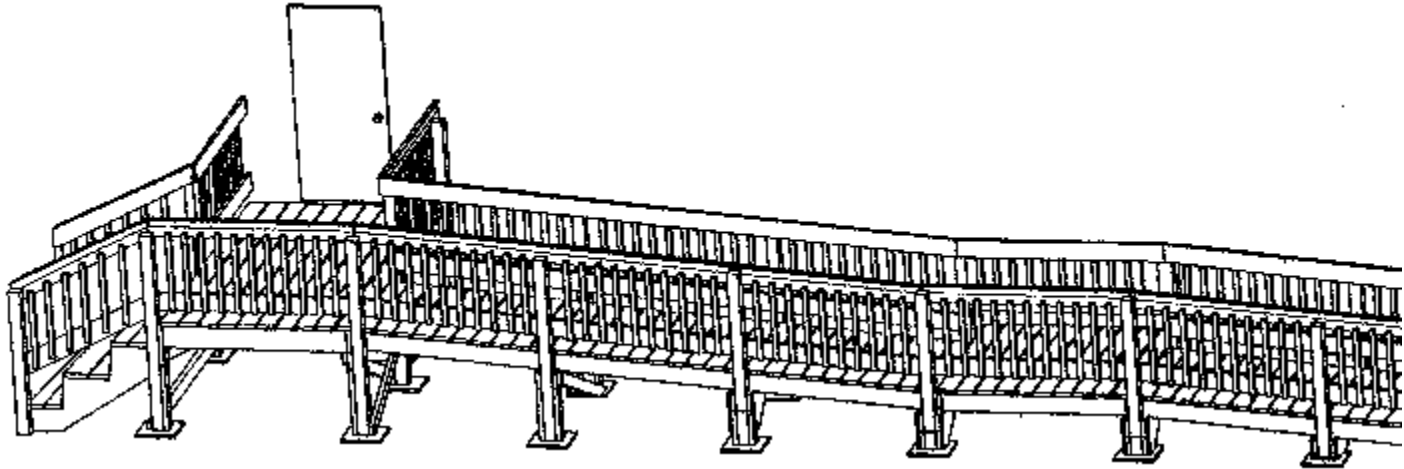

## **RIGHT ANGLE TURN**

- Attach 58"x 60" platform to bottom of Module #3 with 3/8" x 4" carriage bolts. Support platform temporarily with jacks. Make sure the platform is level. Take measurements for length of 4 x 4's, cut 4 x 4's to length, attach pads and place 4 x 4's as in diagram.
- Attach 58"-long cross support with screws on landing side of 4 x 4's at bottom of Module #3 (side A in diagram).
- Attach cross support to 4 x 4's with screws on opposite side of landing (side B in diagram).
- Attach cross support to side C.

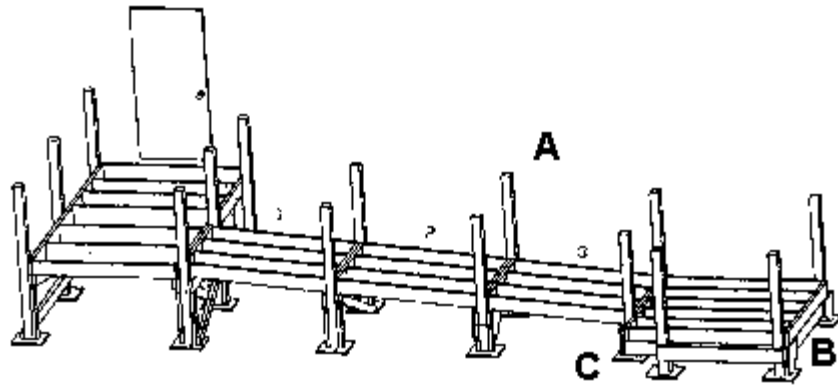

---

NOTE: To build a ramp with a right-angle turn, complete the first section of the ramp as described in previous pages (the lengths of each section do not need to be equal, ex: a 14'6" top section and 9' 8" lower section could be used). Use a 58"x 60" platform and support with 58"-long cross supports.

Five 4 x 4's are used for this landing. (See illustration on [page 36.](#))

All support structure assembly is the same as for sloped sections.

### **Right Angle Turn Transition to Ground**

- Attach string line from top of level landing to point where ramp will end and attach Module #4 in the same manner as described for the top level landing.

**NOTE: The same options for transition to the ground are used for this design.**

Guardrail/handrail options are also the same except an additional 4x4 post is used at the inside corner of the landing so that guardrail can be attached at the corner of the landing.



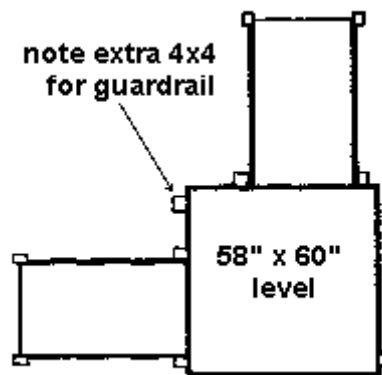
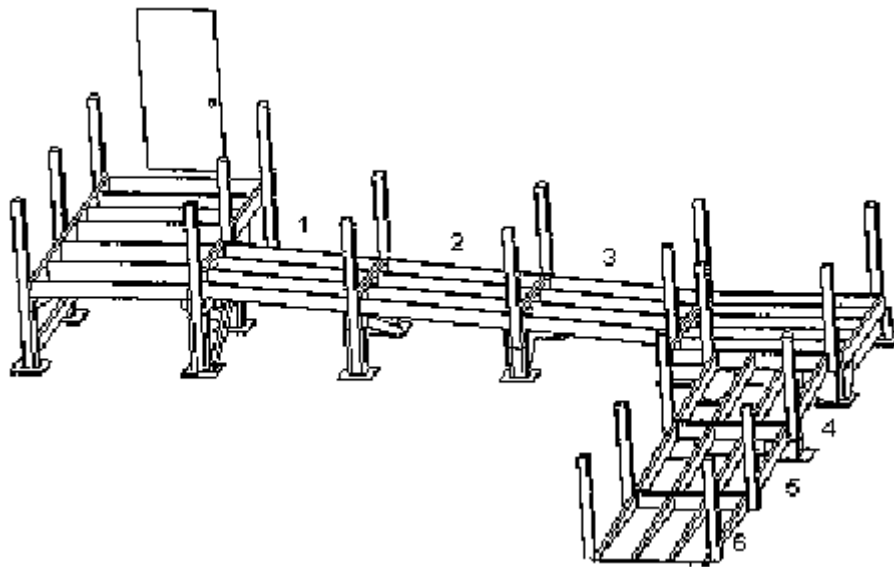

4x4 posts are positioned so that guardrails are above outside 1 1/2" perimeter of landings and slope.  
3" screws are used to attach rail to posts, always inserting screw through rail and then into 4x4

## 180 DEGREE RAMP

To build a ramp with a 180-degree turn, complete the first section of the ramp as described in [previous pages](#) (the lengths of each section do not need to be equal, ex: a 19'4" top section and a 14'6" lower section could be used). Use a 58"x98 1/2" platform and support with 98 1/2" cross supports.

- When attaching cross support for lower end of Module #3, cut 2x6 at 60-degree angle, Attach cross support to 4 x 4's with screws temporarily.

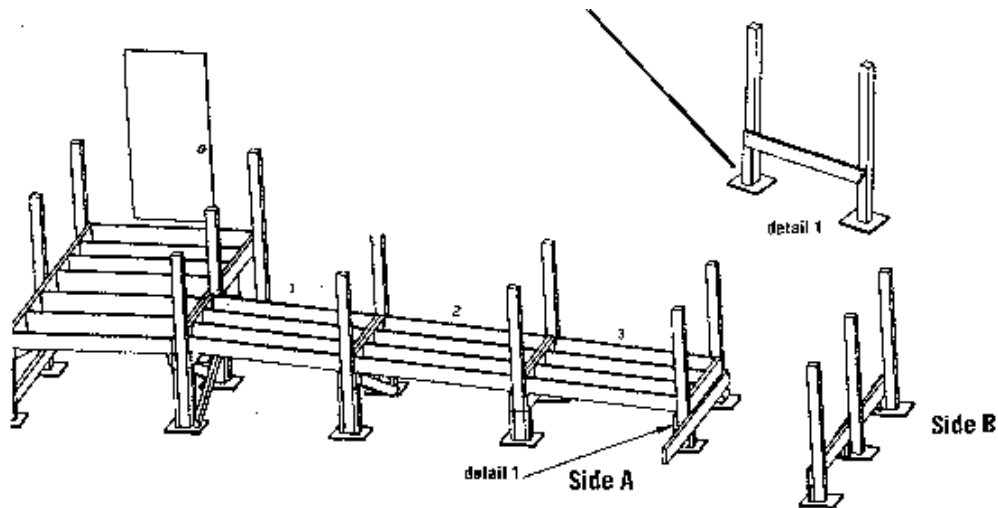

- Attach 98 1/2" cross support to 4 x 4's at end of Module #3. Insure that this cross support is level.
- Drill three 3/8" holes in 58"x98 1/2" landing to match holes in end of Module #3. The end of the level landing will be at the outside edge of the 4x4 so be sure to adjust measurements for hole alignment.
- Attach 58"x 98 1/2" platform to module 3 and support other end with jacks. Level platform and measure for 4 x 4's. Place 4 x 4's on side B as in diagram and attach cross support.
- Attach cross support to side A.
- Put 4x4 for Module #4 in place and attach with deck screws.

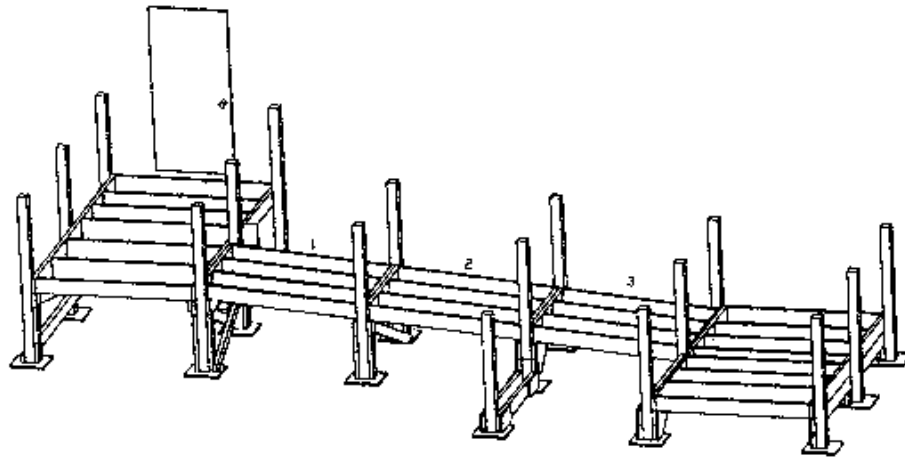

### 180 Degree Ramp Continued

- Attach string line from top of level landing to point where ramp will end.
- Bolt Module #4 to landing with 3/8"x 4" carriage bolts. Match module slope to string.
- Attach cross support for Module #4 as shown in detail 2.
- Cross supports for the junction of Modules #4 and #5 will be attached to the 4x4 at the junction of Modules #2 and #3.

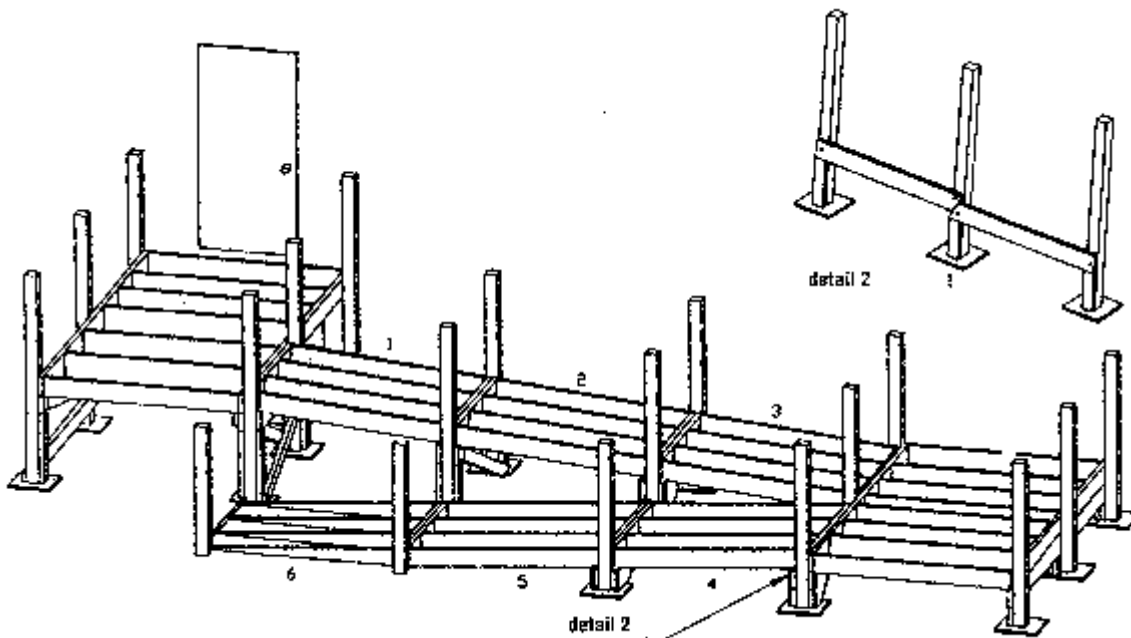

**Note: The same options for transition to the ground are used for this design. Guardrail/handrail options are also the same except the inside guardrail on the lower portion of the ramp will be attached to the center 4 x 4's. Between modules 3 & 4 some 2x2x30" spindles will need to be screwed in place from inside the ramp.**

## **USEFUL TOOLS TO HAVE ON HAND**

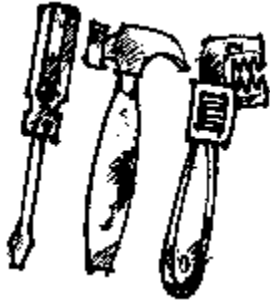

### **Power Miter Saw with 10" Blade**

Very helpful for cutting 4 x 4's and for repetitive same-length cuts such as decking and for angle cuts on guardrail

### **Circular Saw with 7 1/4' Blade**

### **Hand Saw**

### **Block Plane**

### **Saw Horses**

### **3/8" Variable Speed Reversible Drill**

Used for drilling 3/8" holes for driving deck screws

### **1/2" Hammer Drill Variable Speed Reversible**

For tapcons and drilling 9/16" holes (tapcons are cement screws)

### **12" x 9/16 Twist Drill Bit**

For all holes for 1/2" carriage bolts

### **3/8" Twist Drill Bit**

For all 3/8" holes

### **1 1/2" Fly Cut Drill Bit**

Holes & Indentations in Gussets

### **#2 Phillips 1/4" Drive Bits**

Drive Deck Screws

### **#3 Phillips 1/4" Drive Bits**

Drive tapcon screws (use 1/2" drill)

### **Cordless Drills - VSR**

Helpful - not required

### **2' Level**

For plumbing 4 x 4's

### **4" Level**

To level landings & ramp side to side

### **String Level**

To determine slope of ramp

### **String Line**

To align ramp slope

### **Framing Square**

To maintain square modules

### **25' x 1" Tape Measure**

One per worker is helpful

### **Sledge Hammer**

**6' Frost Bar w/tamping head**

For positioning Ramp

**Stanley Bar****Spade or Shovel****Post Hole Digger****Claw Hammers****Vice Grip**

Useful for Removing Screws

w/stripped heads

**3/8" Ratchet Driver****9/16" x 3/8 Deep Socket****3/4" x 3/8 Deep Socket****8" Adjustable Wrench****Power Cords - grounded**

#14 Gauge Minimum

**Safety Goggles****Safety Face Masks****Bumper Jacks**

Useful for positioning landings.

**Maintenance Guidelines**

---

**Maintaining a Non-Slip Surface**

A ramp with a safe slope and spacing between boards for drainage will accommodate weather conditions in cold climates. It is important to ensure the ramp surface remains free of ice and snow. After each snowfall, shovel or sweep the snow off the ramp to prevent accumulation. Quickmelt or similar products can be sprinkled on the ramp surface to prevent ice build-up and reduce slipperiness caused by morning frost.

**Treating Your Ramp**

Treated lumber does not need to be sealed, stained or painted for protection against rotting. Finishing the wood with water repellent sealers or other finishing products will reduce cracking and splitting of the boards. These products can also be used to prevent the wood from appearing weathered or to change the color of the wood. Consult the lumberyard where you purchased the treated wood for advice on products to use.

## **Monitor the Ramp for Changes**

If the user of the ramp notices the wheelchair pulling to one side or the other, the ramp surface may not be horizontal. Raising or lowering the appropriate side of the support structure can correct this.

If a height difference occurs between a landing and a sloped section, an abrupt rise can be created that is not easily traversed. This is also correctable by raising or lowering the support structure.

If any boards splinter or crack, they should be replaced. Also monitor handrails and brackets and replace any loose connections. Be aware of changes in any aspect of your ramp and correct problems as soon as possible,

## **Engineer's Letter on Footing Requirements**

This letter was received in October, 1992 from the engineering firm of Rudin Structures regarding footing requirements.

*We have reviewed your letter from the State of Minnesota Department of Administration regarding your compliance with the State Building Code.*

*At your request, we are furnishing this letter to substantiate our professional opinion that the handicap ramp will not be adversely affected with mud fills located at grade, in lieu of providing footings to the required frost depth. It is our opinion that wood structures of this type are inherently provided with adequate flexibility in their connections to alleviate any additional stress that might be incurred through frost heaving. The cross bracing evaluated by our office did not require the use of frost footings to provide adequate lateral stability. We do recommend, however, that it would be appropriate to review the construction of the ramp on an annual basis to determine if additional shimming below the mud fills is required to maintain the proper slopes of the ramp.*

*Sincerely,*

*Jeffrey S. Kudin, P. E.  
Senior Structural Engineer  
Rudin Structures*

## LONG-TREAD LOW-RISER STEPS

---

PROPERLY DESIGNED RAMPS SHOULD BE CONSIDERED AS THE FIRST CHOICE FOR SAFE WHEELCHAIR MOVEMENT. WHEN A RAMP IS IMPRACTICAL, THE LONG TREAD LOW RISER STEPS PROVIDE A SAFER ALTERNATIVE THAN CARRYING AN OCCUPIED WHEELCHAIR ON REGULAR STEPS.

LONG TREAD, LOW-RISER STEPS ARE NOT APPROPRIATE FOR INDEPENDENT USE BY A PERSON USING A WHEELCHAIR AND ARE NOT INTENDED TO REPLACE PROPERLY DESIGNED RAMPS. ELECTRIC WHEELCHAIRS AND BATTERY POWERED CART SHOULD NOT BE USED WITH THIS TYPE OF STEP.

---

Long-tread low-riser steps have been found to be helpful for people who may use a walker, crutches or canes for assistance in walking or who have difficulty with existing steps to their home. Several examples of this style of step can be seen in ***THE RAMP PROJECT TELECONFERENCE***, which is the video companion to this manual. The long-tread, low-riser steps are most appropriately used by people who have some walking ability, but find regular steps difficult. For the steps to be safe and easy to use, it is very important to determine the correct height of the riser, (the vertical drop between the level treads) for the person who will be using the stairs. It is advisable to check with medical personnel, such as physical therapists, to determine the best riser height. A small variation can make the steps much more difficult to use. Construct the steps with the riser height that is most functional for the user. A range of 3 1/2 inches to 5 inches can be built with the design in this manual.

Be sure that the tread (the level part of the step that you stand on) is long enough to accommodate any assistive devices being used. This is most important for people using a walker, to insure that the walker can be placed with all 4 legs on each tread. The tread length described in this manual is 34" long. Before building the steps make sure that any device being used will fit on the tread and that the intended user will be able to use this type of step.

MINNESOTA BUILDING CODE REQUIRES THAT EITHER TREAD LENGTH OR RISER HEIGHT VARY NO MORE THAN 3/8 OF AN INCH.

TREADS SHOULD BE EQUAL IN LENGTH AND RISERS SHOULD BE AS CLOSE TO EQUAL IN HEIGHT AS POSSIBLE.

## **HOW TO FIND NUMBER OF RISERS AND TREADS NEEDED FOR YOUR LOCATION**

1. Determine proper riser height for person using the steps. Consultation with therapists and trying out various heights is advisable.
2. At the site you have chosen measure the vertical drop from the top landing by the door to ground level.
3. Divide the vertical drop by the riser height you need. Example; 4" riser is needed and there is 30" of vertical drop. 30" divided by 4" equals 7.5. **UNEVEN RISER HEIGHTS ARE NOT ALLOWED** so round 7.5 up to next whole number. You have to have 8 risers.
4. Determine the adjusted riser height for each of the risers in your stairs by dividing vertical drop by number of risers. 30" vertical drop divided by 8 risers equals 3.75" for each riser. .
5. Determine the length of run (how far the treads will extend out from the landing). Multiply the number of treads by 34" which is the length of the module tread. You will have one less tread than risers. 7 treads times 34" per tread equals 238" or 19' 10".
6. Measure 19' 10" from the top landing to where the bottom module will end. Determine the vertical drop from the landing to this point. A string level can be used for this measurement. **IF THIS VERTICAL DROP IS DIFFERENT THAN THE DROP AT LANDING, DUE TO UP OR DOWN VARIATION IN THE TERRAIN YOU HAVE TO RECOMPUTE THE RISERS NEEDED, USING THE AMOUNT OF DROP FOR THE END OF THE STAIRS.** SEE # 3 ABOVE this drawing shows how the 3 1/2" to 5" height range is accomplished. If a 3 1/2" riser is desired, the upper module will touch the lower module, as shown on the right. Higher riser heights are achieved by attaching the lower module to the 4x4 post as much as 1 1/2" lower. This range creates the ability to build equal risers that are best suited to a person's needs.



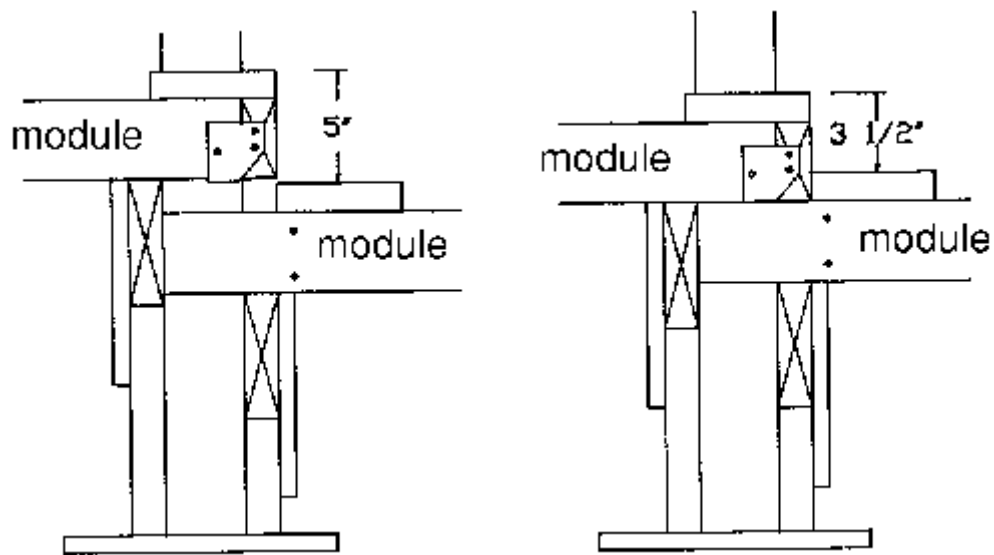

**STANDARD STAIR MODULE** (for tread length of 34" and riser heights between 3 1/2" and 5")

**Components:**

- 1 2x4 by 39" front end piece
- 2 2x4 by 37 1/2" outside joists
- 1 2x4 by 36" back end piece
- 2 2x4 by 31" inside joists
- 6 5/4"x6" by 39" decking  
(order two 10' decking and cut 39" long pieces from them)
- 48 2 1/2" deck galvanized deck screws (8 per decking plank)
- 16 3" galvanized deck screws (to attach end pieces to joists)
- 8 2x4 joist hangers
- 4 3" galvanizes deck screws (to attach front end piece joist hanger)
- 48 joist hanger nails

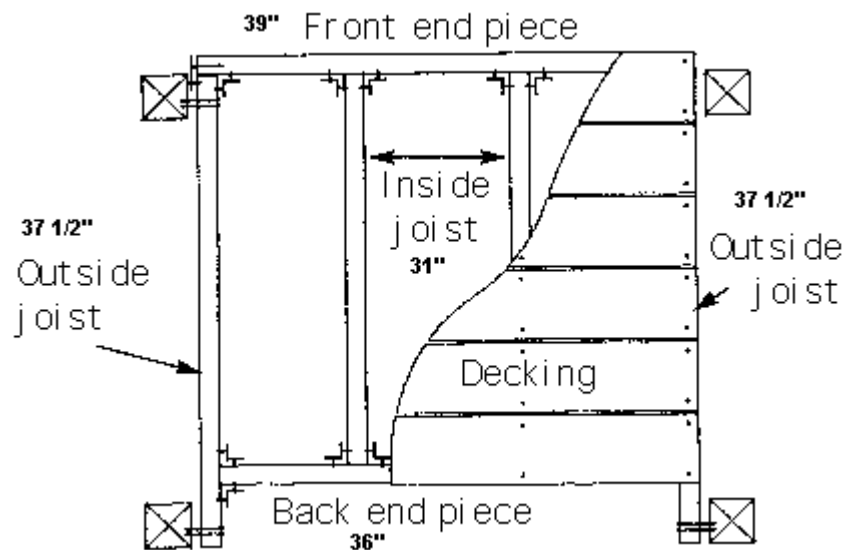

### Construction Notes:

1. Cut joists and end pieces to length and assemble on flat surface. Space joists 13" apart on center.
2. Screw end pieces to the ends of joists with 3" screws.
3. Insure module is square and nail on joist hangers.
4. Bend outside flange of the 2 front corner joist hangers flat against end piece and use 3" screws instead of nails to attach the flange to the end of the front end piece
5. Decking is attached after the module is in place, because you into the 4 x 4 support posts when hanging the module.

When attaching a step to a landing made with 2 x 6s, make the outside joists of the step module 34" long instead of 37 1/2" long. This allows the 34" tread length to be maintained.

### Taller Support Structure (for 39" modules)

Used when distance between top of cross support and plywood pad exceeds 21"

### Components:

- 2 4x4 Support Posts (Length-determined by height requirements of stairs)

- 2 1' x 1' by 3/4" Treated Plywood Pads (Will be screwed to bottom of 4x4 with three 3" deck screws)
- 2 2x6 by 45 1/2" Cross Supports
- 4 2x4 Trimmers (Length equals distance between bottom of cross support and plywood pad.) (Trimmers will be screwed to 4x4.)
- 2 2x4 Diagonal Braces (Length will be determined by height of cross support)

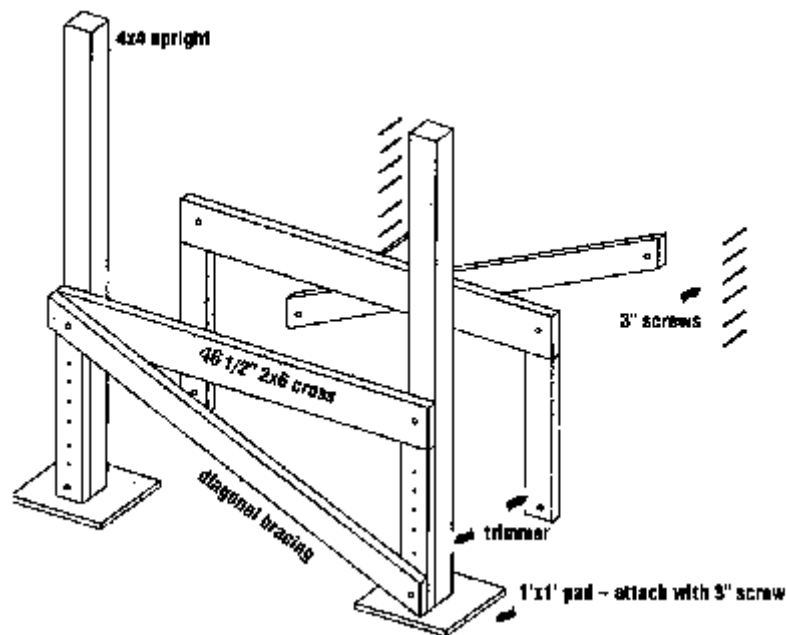

**Construction Notes:**

1. 4 x 4's support the stair module, guardrails and handrail
2. A standard guardrail height of 36" can be obtained by having 34" of 4x4 extend above the stair surface. Compute the length of each 4x4 upright by measuring down from the stair surface at front of module to plywood pad on the ground and add 34" to that number.
3. The two legs are often not the same length due to uneven terrain.
4. The cross supports are an extra 1/2" long to allow space to easily set modules in place.
5. During construction, be sure that 4 x 4s are plumb and cross supports are horizontal before installing trimmers, gussets and bracing. Temporarily attach cross supports with screws to allow for adjustments and place bracing and gussets after all modules are in place.

## Shorter Support Structure (for 39" modules)

Used when distance between top of cross support and 1'x1'x 3/4" pad is 12" to 21"

### Components:

- 2 4x4 Support Posts (Length-determined by height requirements of stair)
- 2 1' x 1' by 3/4" Treated Plywood Pads (Will be screwed to bottom of 4x4 with three 3" deck screws)
- 2 2x6 46 1/2" Cross Supports for 39" module
- 4 2x4 Trimmers (Length equals distance between bottom of cross support and plywood pad.) (Trimmers will be screwed to 4x4.)
- 4 3/4"-thick Treated Plywood Gussets (see drawing for dimensions) (Gussets will be screwed to trimmer and cross supports with seven screws per gusset.) use 2 1/2" screws

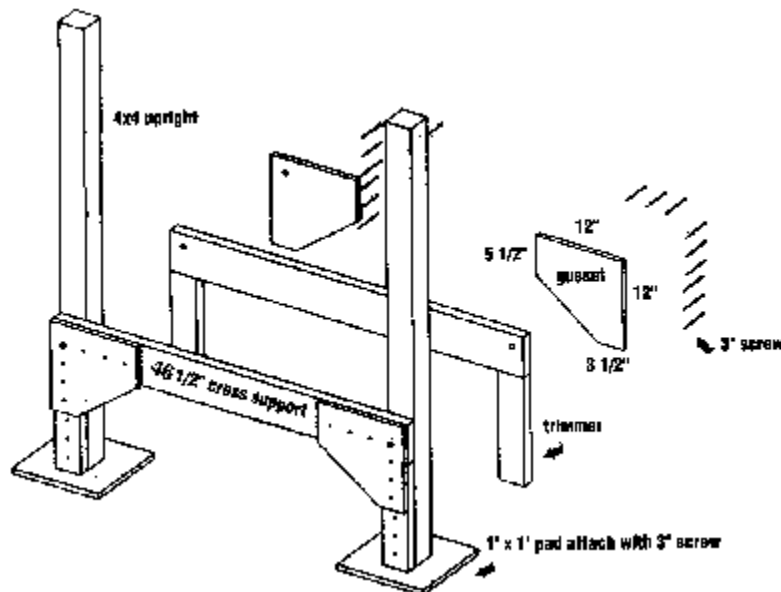

### Construction Notes:

1. 4 x 4's support the stair module, guardrails and handrail
2. A standard guardrail height of 36" can be obtained by having 34" of 4x4 extend above the stair surface. Compute the length of each 4x4 upright by measuring down from the stair surface at front of module to plywood pad on the ground and add 34" to that number.
3. The two legs are often not the same length due to uneven terrain.

4. The cross supports are an extra 1/2" long to allow space to easily set modules in place.
5. During construction, be sure that 4 x 4s are plumb and cross supports are horizontal before installing trimmers, gussets and bracing. Temporarily attach cross supports with screws to allow for adjustments and place bracing and gussets after all modules are in place.

## **Long-Tread Stair Construction Procedures**

The building process for these steps is very similar to the process to build ramps. The same considerations for landings at the door and starting construction at the top and progressing down in a progressive fashion apply. Note that neither 3/8" bolts nor 1/2" bolts are called for in the engineering documents for the long-tread low-riser steps.

## **TO HANG STAIR MODULES**

1. Build the level landing at door.
2. Attach two 4 x 4s 39 1/2" apart to the top landing to create the opening for the first step module.
3. Place the first module at the height needed to achieve your chosen riser height. Remember that you will be adding decking to the module, so allow for the 1 1/4" thickness of the decking.
4. Attach the module to the 2 4 x 4's with one 3" deck screw on each side. The positioning of the module onto the 4 x 4s is shown.

**Note that the front 4x4 is 1 1/2" from the front of the module. Also note the 1 1/2" gap between the rear cross piece and the rear 4x4. This gap allows for the 3 1/2" minimum riser height.**

5. After making sure the module is level from side to side, raise or lower the front of the module to a level position.
6. Place the next pair of 4 x 4's in position and attach module to them with two 3" screws on each side.
7. add another 3" screw to each of the back 4 x 4s.

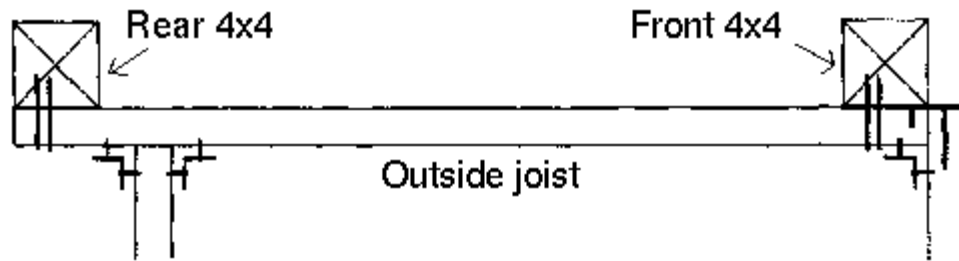

8. Install 2x6 cross supports using 2 3" screws to attach them to 4 x 4s. Do not add trimmers, bracing and gussets until all modules are in place and you are sure all risers will be equal and level.
9. Module is now being held in place by the cross supports. Measure down for the next riser height and install the next module in the same manner.
  
10. After all modules have been installed and you have determined that all riser heights are equal and modules are level, add the trimmers, braces if needed and gussets. Diagonal bracing requires 2 3" screws at each attachment point. Trimmers fit between the bottom of the 2x6 cross support and the 1 square foot plywood plate and have to fit snugly, because they are weight bearing. Trimmers require 3" screws to be 6" apart vertically. Gussets require seven 2 1/2" screws.
11. Place decking on modules and attach with 2 1/2" screws
12. Install guard rail and handrail using same techniques as described for ramps on.

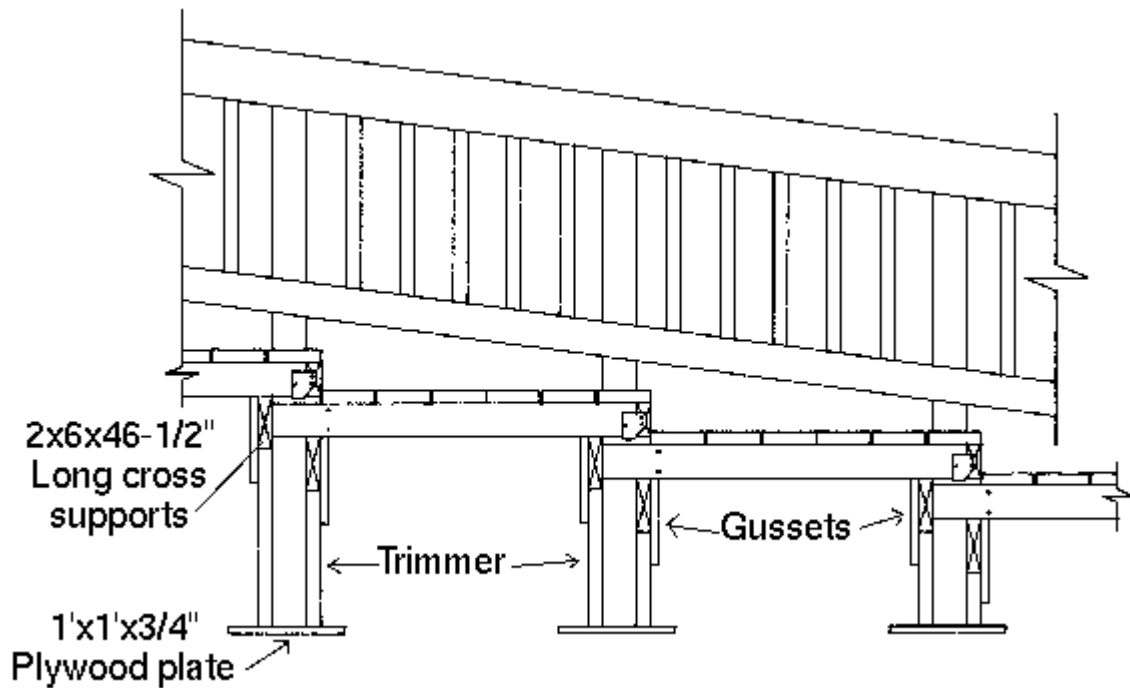

### Long-Tread Stair Final Notes

When working over concrete, you will need to cut down the height of the bottom module, if your riser height is less than  $4 \frac{3}{4}$ " high because the module with decking on it has a  $4 \frac{3}{4}$ " riser. Make a shorter module by cutting all module 2 x 4's to the height needed. Remember to compute the  $1 \frac{1}{4}$ " thickness of the decking. If the module height is reduced, brace the two front bottom 4 x 4s as shown. You can also use this bracing for guardrail stability, even if the module is not shortened.

Modify a standard stair module using a 63" front end piece instead of a 39". Set module in place and attach 4 x 4s with 3" screws.

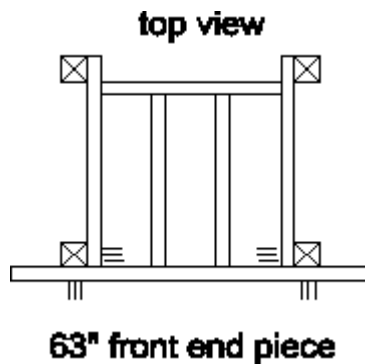

Cut a 45 degree angle on one end of a 2x4 and place it on one end of the 63" front end piece. Mark and cut the 2x4 on the inside edge of the 4x4. (also a 45 degree cut) Attach the 2x4 brace with 3" screws as shown. Repeat on other side.

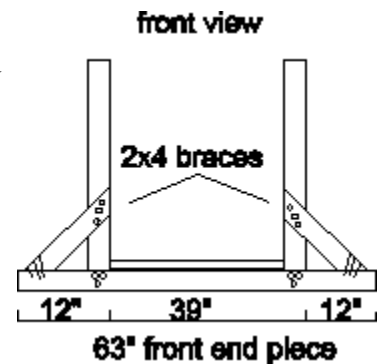

You may have to remove dirt to achieve the proper riser heights when not building over a hard surface such as concrete. You may rest the module on 39" long 2x6 boards laid underneath and across each end of the module. Be sure to attach module to those boards by toe-nailing screws through the end pieces into the 2x6. The two front bottom 4 x 4s can be placed in 24" deep post holes to provide stability for the guardrail.

Boardwalk can be installed if desired. Be sure the riser height is equal for all steps, including the one to the boardwalk.

### **Safety Advisory**

Placing reflective tape or painting a brightly colored strip on the nose of each long-tread low-riser step will make it easier for users to see where each riser is, especially in low light conditions. We recommend adding a visual marker to each step to reduce the chances of tripping for everyone using the steps.

### **Final Words**

This manual was made possible by a Minnesota Housing Finance Agency Grant with additional funding from the Minnesota Division of Rehabilitation Services to the Metropolitan Center for Independent Living. The goal of the grant is to make this ramp information available to as many people as possible. When making copies, please credit MCIL.

This manual is stored in the Home Ramp Project website and can be downloaded. To connect with the website go to - <http://www.wheelchairramp.org>.

This manual is also available on tape, disc and in Braille.

Ramp project personnel are interested in receiving suggestions and ideas regarding this manual and ramp building. Of special interest are the experiences of groups trying to increase the ramp building capacity in their communities.